

UNCONTROLLED

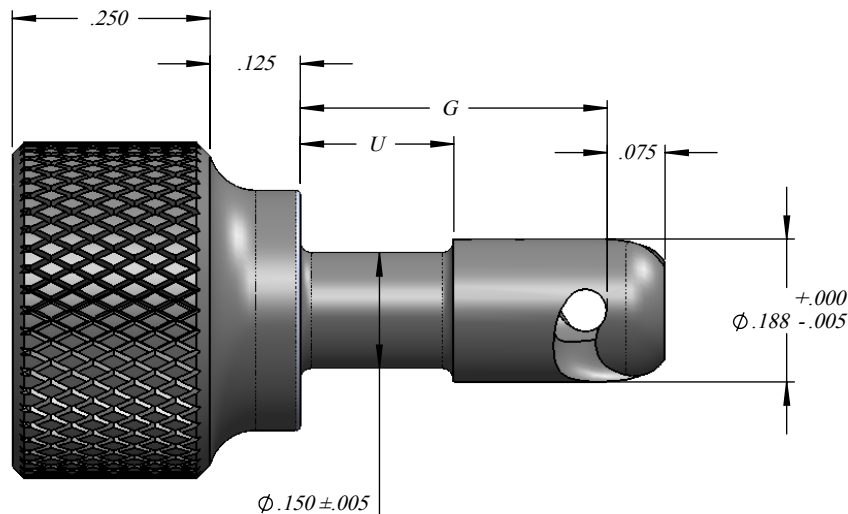
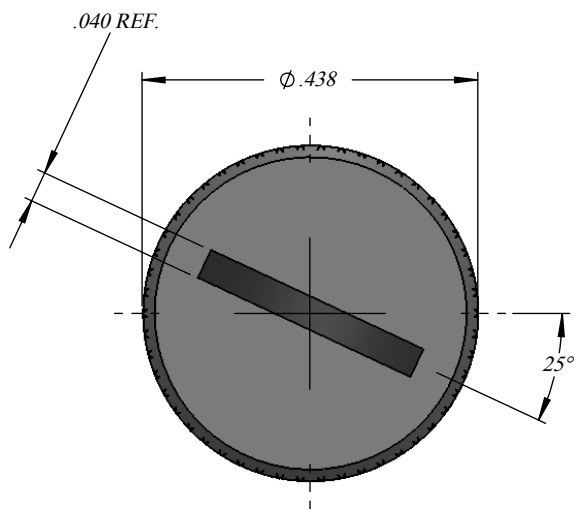
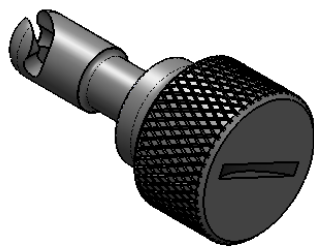

REVISIONS			
SYS	DESCRIPTION	DATE	APPROV
A	INITIAL RELEASE	05/18/20	F.B

MATERIAL: A.I.S.I 8620 OR TYPE 303 STAINLESS STEEL

HEAT TREAT: ROCKWELL C 30-35

FINISH: NOTED

THE FASTENER PARTS SHOWN IN THIS PRINT ARE PROPRIETARY ARTICLES TO WHICH DFCI SOLUTIONS INC., RETAINS THE EXCLUSIVE RIGHTS OF MANUFACTURE, USE AND SALE. THE PRINT OR DRAWING IS SUBMITTED IN CONFIDENCE AND DOES NOT CONVEY A LICENSE OR PERMISSION TO MANUFACTURE THE FASTENER OR FASTENER PARTS.

(C) COPYRIGHT 2009, DFCI SOLUTIONS INC. ALL RIGHTS RESERVED.

TOLERANCES ON DIMENSIONS UNLESS OTHERWISE SPECIFIED

X* = ±2° .XX = ±.015
 X/X = ±1/32 .XXX = ±.010

MACHINE FINISH = .125

PART NO.	DRN	DATE
	W. Zhindon	05/18/10
	CHK. Frank Basile	05/18/10
	ENG. Peter Altkorn	05/18/10
	MFG. Bill Velazquez	05/18/10
	Q.C. Peter Altkorn	05/18/10
NEXT ASSY	USED ON	SALES.
APPLICATION BLOCK		



DFCI SOLUTIONS INC.
 425 UNION BOULEVARD.
 WEST ISLIP, NEW YORK 11795

TITLE: ST-1200 LINE KNURLED HEAD STUD
 1211-3xx-Z3CT

SIZE	FSCM NO	DWG. NO.	REV.
A	72794	C1211-3	A

SCALE: NTS WEIGHT: SHEET 1 OF 2

UNCONTROLLED

REVISIONS			
SYS	DESCRIPTION	DATE	APPROV
A	INITIAL RELEASE	05/18/20	F.B

PART NO.	G	U
1211-320-Z3CT	.200	.075
1211-325-Z3CT	.250	.075
1211-330-Z3CT	.300	.100
1211-335-Z3CT	.350	.150
1211-340-Z3CT	.400	.200
1211-350-Z3CT	.500	.250
1211-360-Z3CT	.600	.300
1211-365-Z3CT	.650	.350
1211-370-Z3CT	.700	.350
1211-380-Z3CT	.800	.400
1211-390-Z3CT	.900	.500
1211-3100-Z3CT	1.000	.500
1211-3110-Z3CT	1.100	.500
1211-3120-Z3CT	1.200	.500

NOTES:

1. FINISH:
ZINC PLATE PER ASTM-B-633, TYPE III, SC 2, CLEAR TRIVALENT CHROMATE WITH SEALER. (RoHS COMPLIANT) FINISH SUFFIX: -Z3CT.
2. FOR PART NO. OF STUD MADE FROM ST. STEEL, REMOVE SUFFIX -Z3CT FROM PART NUMBER AND ADD "-SS" EXAMPLE 1211-320-SS.
3. FOR THE APPLICATION OF ALTERNATIVE FINISHES, REMOVE SUFFIX -Z3CT FROM THE PART NO. AND ADD THE REQUIRED FINISH TO THE PART NO. SUFFIX. "EXAMPLE FOR BLACK ZINC TRIVALENT CHROMATE FINISH, THE PART NO. IS 1211-320-Z3BT.
4. PLEASE VISIT WWW.DFCIS.COM/C1211-3 FOR A LIST OF AVAILABLE FINISHES.

MATERIAL: A.I.S.I 8620 OR TYPE 303 STAINLESS STEEL		TOLERANCES ON DIMENSIONS UNLESS OTHERWISE SPECIFIED				 DFCI SOLUTIONS INC. 425 UNION BOULEVARD. WEST ISLIP, NEW YORK 11795	
HEAT TREAT: ROCKWELL C 30-35		X* = ±2° .XX = ±.015 X/X = ±1/32 .XXX = ±.010 MACHINE FINISH = .125					
FINISH: NOTED		PART NO.	DRN	DATE	TITLE ST-1200 LINE KNURLED HEAD STUD 1211-3xx-Z3CT		
THE FASTENER PARTS SHOWN IN THIS PRINT ARE PROPERTY ARTICLES TO WHICH DFCI SOLUTIONS INC., RETAINS THE EXCLUSIVE RIGHTS OF MANUFACTURE, USE AND SALE. THE PRINT OR DRAWING IS SUBMITTED IN CONFIDENCE AND DOES NOT CONVEY A LICENSE OR PERMISSION TO MANUFACTURE THE FASTENER OR FASTENER PARTS. (C) COPYRIGHT 2009, DFCI SOLUTIONS INC. ALL RIGHTS RESERVED.			W. Zhindon	05/18/10			
			Frank Basile	05/18/10			
			Robert Albrecht	05/18/10			
			Bill Velazquez	05/18/10			
	Q.C.	DATE	05/18/10	SIZE	FSCM NO	DWG. NO.	REV.
	NEXT ASSY	USED ON	SALES.	A	72794	C1211-3	A
APPLICATION BLOCK				SCALE: NTS		WEIGHT:	SHEET 2 OF 2