

UNCONTROLLED

REVISIONS			
SYM	DESCRIPTION	DATE	APPROV
A	INITIAL RELEASE PER ECN 845.	5-31-07	R. OLSEN

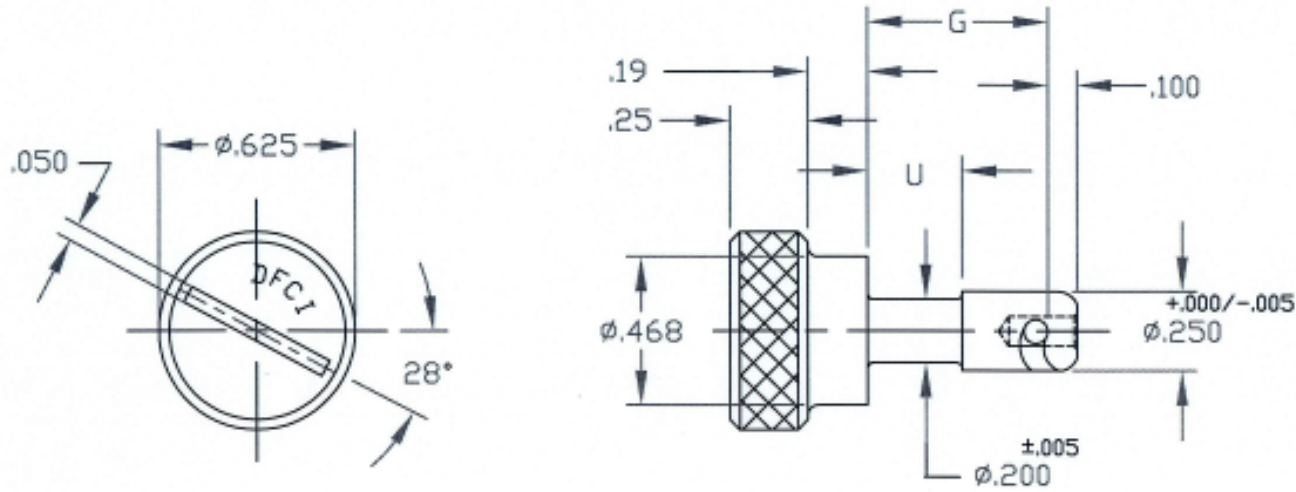

FOR PART NO. REFER TO SHEET 2of2.

MAT'L PER A.I.S.I 8620 STEEL OR TYPE 303 ST. STEEL. HEAT TREAT PER NOTE 3. FINISH PER NOTE 1.		TOLERANCES ON DIMENSIONS UNLESS OTHERWISE SPECIFIED X = ±.005 .XX = ±.015 X/X = ±1/32 .XXX = ±.010 MACHINE FINISH 125T		DFCI SOLUTIONS INC. 425 UNION BOULEVARD WEST ISLIP, NEW YORK 11795	
PART NO. _____ NEXT ASSY _____ USED ON _____ APPLICATION BLOCK _____		DRN S. FRANKS DATE 5-31-07 CHK F. Basil DATE 6-1-07 ENG R. OLSEN DATE 6/1/07 MFG B. Hill DATE 6/1/07 QC B. Hill DATE 6/1/07		TITLE ST-1200 KNURL HD. STUD, 1211-4xx-24247-Z3CT SIZE A FSCM NO 72794 DWG. NO. C1211-4-24247 REV. A	
DATE: 07/01/06 FORM: DRAWING		SCALE NTS WT. _____		SHEET 1 OF 2	

UNCONTROLLED

REVISIONS			
SYM	DESCRIPTION	DATE	APPROV
A	INITIAL RELEASE PER ECN 845.	5-31-07	R. OLSEN

PART NO. (8620 STEEL STUD)	G	U
1211-430-24247-Z3CT	.300	.100
1211-435-24247-Z3CT	.350	.150
1211-440-24247-Z3CT	.400	.200
1211-440B25024247-Z3CT	.400	.250
1211-445-24247-Z3CT	.450	.225
1211-450-24247-Z3CTSL	.500	.250
1211-455-24247-Z3CT	.550	.300
1211-460B10024247-Z3CT	.600	.100
1211-470-24247-Z3CT	.700	.350
1211-475-24247-Z3CT	.750	.400
1211-480-24247-Z3CT	.800	.400
1211-4100-24247-Z3CT	1.000	.600
1211-4110-24247-Z3CT	1.100	.600

NOTES:

1. FINISH:
ZINC PLATE PER ASTM-B-633, TYPE III, SC 2, CLEAR TRIVALENT CHROMATE WITH SEALER. (RoHS COMPLIANT) FINISH SUFFIX: -Z3CT
THE ABOVE MENTIONED FINISH WILL BE SUPPLIED AS THE STANDARD FINISH, UPON DEPLETION OF EXISTING STOCK WHICH ARE FINISHED AS FOLLOWS: ZINC PLATE PER ASTM-B-633, TYPE III, SC 2, CLEAR CHROMATE. FINISH SUFFIX -Z3C.
2. HEAT TREATMENT:
STEEL STUD ONLY: ROCKWELL C27 - 33.
3. FOR PART NO. OF STUD MADE FROM ST. STEEL, REMOVE SUFFIX -Z3CT FROM P/N AND ADD '-SS' EXAMPLE 1211-430-24247-SS.
4. FOR THE APPLICATION OF ALTERNATIVE FINISHES, REMOVE SUFFIX -Z3CT FROM THE PART NO. AND ADD THE REQUIRED FINISH TO THE PART NO. SUFFIX. *EXAMPLE FOR BLACK ZINC TRIVALENT CHROMATE FINISH, THE PART NO. IS 1211-430-24247-Z3BT.
5. PLEASE VISIT WWW.DFCIS.COM/C1211-4-24247 FOR A LIST OF AVAILABLE FINISHES.

MAT'L PER A.I.S.I 8620 STEEL OR TYPE 303 ST. STEEL.		TOLERANCES ON DIMENSIONS UNLESS OTHERWISE SPECIFIED X = ±2" .XX = ±.015 X/X = ±1/32 .XXX = ±.010		MACHINE FINISH 1257		 DFCI SOLUTIONS INC. 425 UNION BOULEVARD WEST ISLIP, NEW YORK 11795	
HEAT TREAT PER NOTE 3.		PART NO.		DRN S. FRANCIS DATE 5-31-07		TITLE ST-1200 KNURL HD. STUD, 1211-4xx-24247-Z3CT	
FINISH PER NOTE 1.		CHK F. Basil DATE 6-1-07		ENG R. OLSEN DATE 4/4/07		SIZE A FSCM NO 72794 DWG. NO. C1211-4-24247 REV. A	
THE FASTENER PARTS SHOWN ON THIS PRINT ARE PROPRIETARY ARTICLES TO WHICH DFCI SOLUTIONS INC. RETAINS THE EXCLUSIVE RIGHTS OF MANUFACTURE, USE AND SALE. THE PRINT OR DRAWING IS SUBMITTED IN CONFIDENCE AND DOES NOT CONVEY A LICENSE OR PERMISSION TO MANUFACTURE THE FASTENER OR FASTENER PARTS.		MFG DATE 6/4/07		SALES DATE		SCALE NTS WT. SHEET 2 OF 2	
DATE: 07/01/08 FORM: DRAWING		APPLICATION BLOCK		NEXT ASSY USED ON		DATE	