

REVISIONS			
SYS	DESCRIPTION	DATE	APPROV
A	PER ECN 845 & 1168	10/16/14	

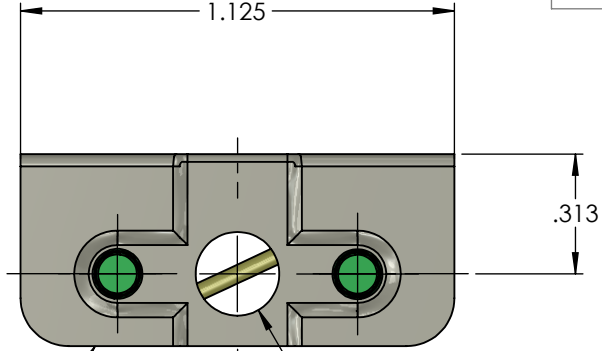

PART NUMBER	"H" DIMENSION
1218-P3205-Z3CT	.205
1218-P3230-Z3CT	.230
1218-P3255-Z3CT	.255
1218-P3280-Z3CT	.280

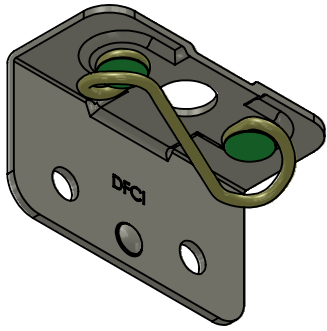
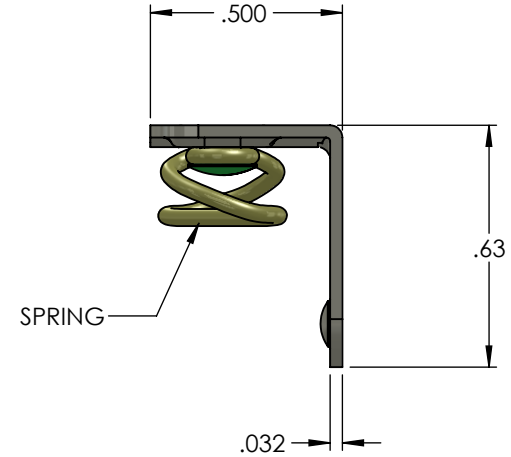
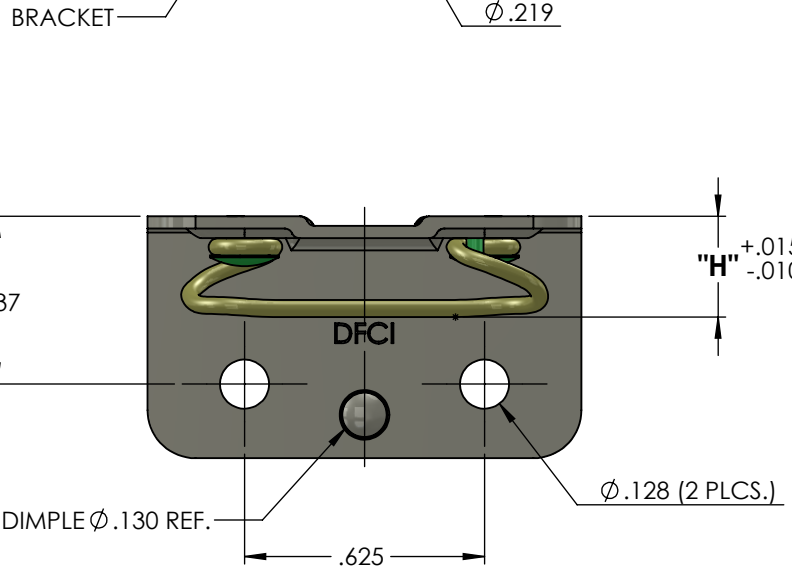

UNCONTROLLED

MATERIAL:	BRACKET: C1010 STEEL SPRING: MUSIC WIRE
HEAT TREAT:	NONE
FINISH:	ZINC PLATED PER ASTM-B-633, TYPE III, SC2 CLEAR TRIVALENT CHROMATE WITH SEALER
<small>THE FASTENER PARTS SHOWN IN THIS PRINT ARE PROPRIETARY ARTICLES TO WHICH DFCI SOLUTIONS INC., RETAINS THE EXCLUSIVE RIGHTS OF MANUFACTURE, USE AND SALE. THE PRINT OR DRAWING IS SUBMITTED IN CONFIDENCE AND DOES NOT CONVEY A LICENSE OR PERMISSION TO MANUFACTURE THE FASTENER OR FASTENER PARTS.</small> (C) COPYRIGHT 2009, DFCI SOLUTIONS INC. ALL RIGHTS RESERVED.	

TOLERANCES ON DIMENSIONS UNLESS OTHERWISE SPECIFIED			
X° = ±2°	.XX = ±.015	MACHINE FINISH = .125	
X/X = ±1/32	.XXX = ±.010		
PART NO.	SEE TABLE	DRN	DATE
		Frank Basile	10/16/14
		CHK.	DATE
		Frank Basile	10/16/14
		ENG.	DATE
		Robert Altkorn	10/16/14
		MFG.	DATE
		Rashid Lubman	10/16/14
		G.C.	DATE
		Robert Altkorn	10/16/14
NEXT ASSY	USED ON	SALES.	DATE

		DFCI SOLUTIONS INC. 425 UNION BOULEVARD. WEST ISLIP, NEW YORK 11795	
TITLE: ST-1200 RIGHT ANGLE RECEPTACLE 1218-P3***-Z3CT			
SIZE	FSCM NO.	DWG. NO.	REV.
A	72794	C1218-P3	A
SCALE: NTS		WEIGHT:	SHEET 1 OF 1