

UNCONTROLLED

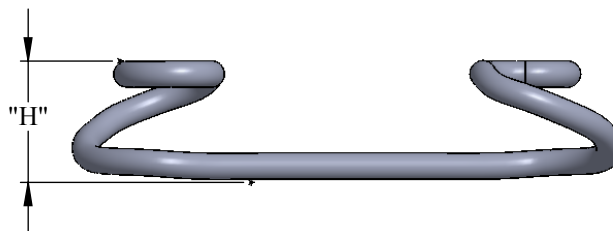
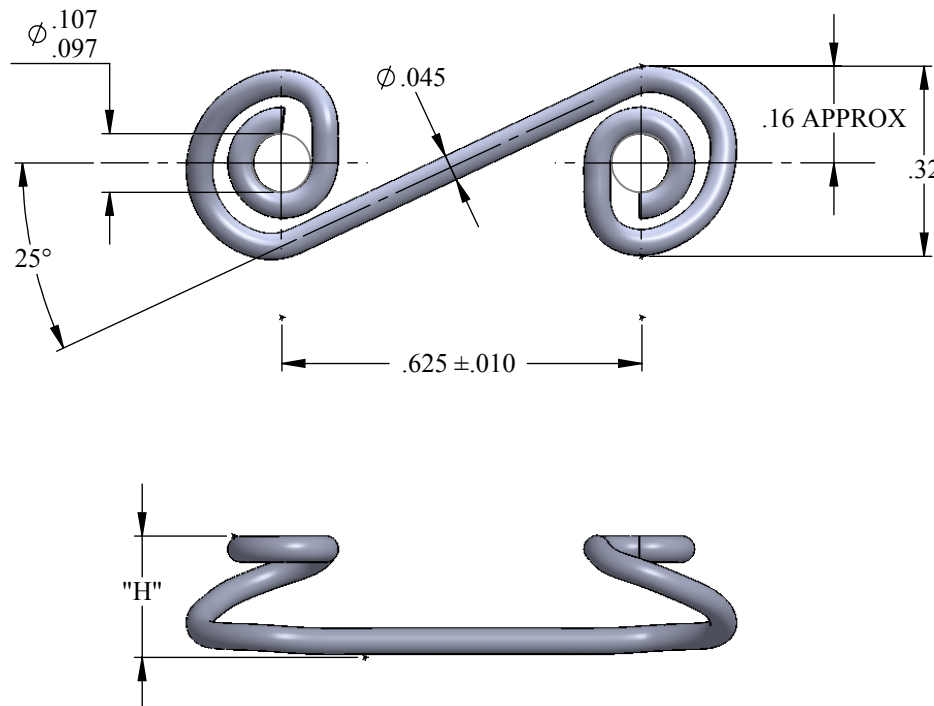
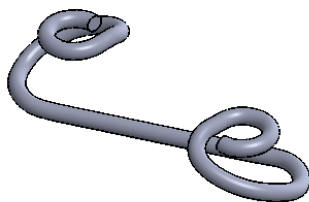

FOR PART NO. REFER TO SHEET 2 OF 2

REVISIONS			
SYS	DESCRIPTION	DATE	APPROV
F	PER ECN 1168	03/01/10	F.B.

MATERIAL: .045 DIA. MUSIC WIRE PER ASTM-A-228 OR TYPE 300 SERIES ST. STEEL

HEAT TREAT: SPRING MADE FROM MUSIC WIRE OR ST. STEEL ARE NOT HEAT TREATED

FINISH: PER NOTE 1.

THE FASTENER PARTS SHOWN IN THIS PRINT ARE PROPRIETARY ARTICLES TO WHICH DFCI SOLUTIONS INC., RETAINS THE EXCLUSIVE RIGHTS OF MANUFACTURE, USE AND SALE. THE PRINT OR DRAWING IS SUBMITTED IN CONFIDENCE AND DOES NOT CONVEY A LICENSE OR PERMISSION TO MANUFACTURE THE FASTENER OR FASTENER PARTS.

(C) COPYRIGHT 2009, DFCI SOLUTIONS INC. ALL RIGHTS RESERVED.

TOLERANCES ON DIMENSIONS UNLESS OTHERWISE SPECIFIED

X\* = ±2° .XX = ±.015  
X/X = ±1/32 .XXX = ±.010

MACHINE FINISH = .125

PART NO.	DRN	DATE
	W. Zhindon	03-01-2010
	CHK.	DATE
	Frank Basile	03-01-2010
	ENG.	DATE
	Robert Altkorand	03-03-2010
	MFG.	DATE
	Bill Velazquez	03-02-2010
	G.C.	DATE
	Robert Altkorand	03-03-2010
NEXT ASSY	USED ON	SALES



DFCI SOLUTIONS INC.

425 UNION BOULEVARD.  
WEST ISLIP, NEW YORK 11795

TITLE	ST-1200 SIZE 3 SPRING, 1219-3xxx-Z3CT
SIZE	A
FSCM NO.	72794
DWG. NO.	C1219-3
REV.	F

SCALE: NTS

WEIGHT:

SHEET 1 OF 2

