

UNCONTROLLED

C1219-B42 REV. A

REVISIONS			
SYM	DESCRIPTION	DATE	APPROV
A	INITIAL RELEASE PER 845.	2-14-08	R. OLSEN

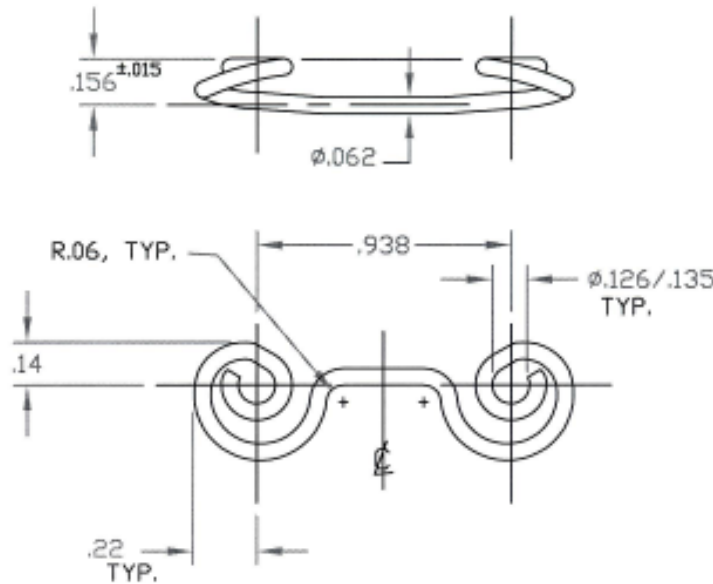

NOTES:

- FINISH:**
ZINC PLATE PER ASTM-B-633, TYPE III, SC 2, CLEAR TRIVALENT CHROMATE WITH SEALER. (RoHS COMPLIANT) FINISH SUFFIX: -Z3CT
THE ABOVE MENTIONED FINISH WILL BE SUPPLIED AS THE STANDARD FINISH UPON DEPLETION OF EXISTING STOCK WHICH ARE FINISHED AS FOLLO:
ZINC PLATE PER ASTM-B-633, TYPE II, SC 2. YELLOW CHROMATE. (FINISH SUFFIX: -Z3Y)
- FOR THE APPLICATION OF ALTERNATIVE FINISHES, REMOVE SUFFIX -Z3CT FROM THE PART NO. AND ADD THE REQUIRED FINISH TO THE PART NO. SUFFIX. *EXAMPLE FOR BLACK ZINC TRIVALENT CHROMATE THE P/N WILL BE 1219-B42-Z3BT.
- PLEASE VISIT WWW.DFCIS.COM/C1219-B42 FOR A LIST OF AVAILABLE FINISHES.

PART NO.	MATERIAL	FINISH
1219-B42-Z3CT	MUSIC WIRE PER ASTM-228.	PER NOTE 1
1219-B42-SS	TYPE 316 ST. STEEL. SPRING TEMPER.	NATURAL

MAT'L AS NOTED	TOLERANCES ON DIMENSIONS UNLESS OTHERWISE SPECIFIED X* = ±2* .XX = ±.015 X/X = ±1/32 .XXX = ±.010 MACHINE FINISH 125T		DFCI SOLUTIONS INC. 425 UNION BOULEVARD WEST ISLIP, NEW YORK 11795	
HEAT TREAT NONE.	PART NO.	DRN S. FRANKS	DATE 2-14-08	TITLE ST-1200 LINE SPRING, 1219-B42-Z3CT.
FINISH PER NOTE 1.		CHK F. Basch	DATE 2-19-08	SIZE A
		ENG R. OLSEN	DATE 2/19/08	FSCM NO 72794
		MFG D. Nilsen	DATE 2/19/08	DWG. NO. C1219-B42
	NEXT ASSY	USED ON	DATE	REV. A
	SALES	DATE	SCALE NTS	WT.
APPLICATION BLOCK			SHEET 1 OF 1	

DATE: 07/01/06 FORM: DRAWING