

**NOTES:**

1. FINISH: ZINC PLATE PER ASTM-B-633, TYPE III, SC2 CLEAR TRIVALENT CHROMATE WITH SEALER.
2. PLEASE VISIT [www.dfci.com/C1219-D3](http://www.dfci.com/C1219-D3) FOR A LIST OF AVAILABLE FINISHES.

REVISIONS			
SYS	DESCRIPTION	DATE	APPROV
A	PER ECN 845 & 1168	10/10/13	

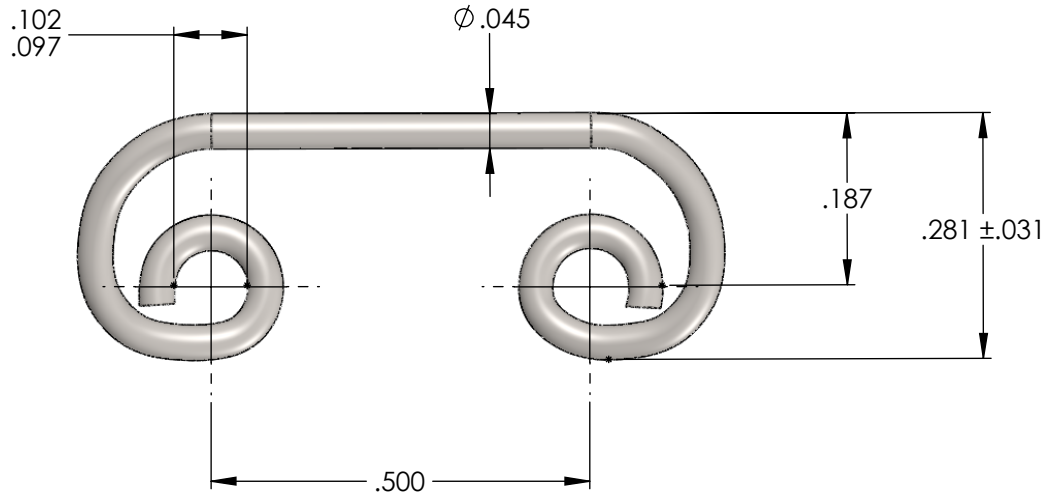

PART NUMBER	"H" DIMENSION
1219-D3140-Z3CT	.140
1219-D3175-Z3CT	.175

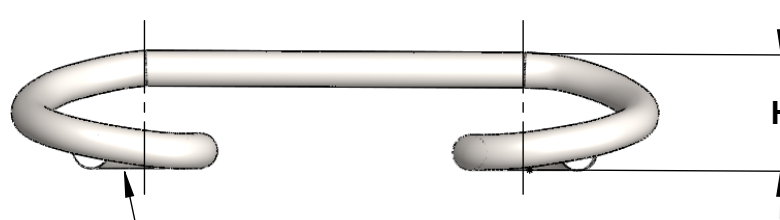

SPRING SEATS TO BE FLAT FOR APPROX. 270°

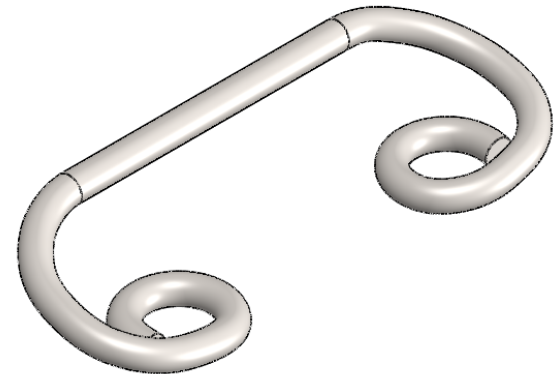

**UNCONTROLLED**

MATERIAL: MUSIC WIRE PER ASTM-A-228		TOLERANCES ON DIMENSIONS UNLESS OTHERWISE SPECIFIED X° = ±2° .XX = ±.015 X/X = ±1/32 .XXX = ±.010 MACHINE FINISH = .125				 <b>DFCI SOLUTIONS INC.</b> 425 UNION BOULEVARD. WEST ISLIP, NEW YORK 11795	
HEAT TREAT: NONE		PART NO. SEE TABLE	DRN Frank Basile	DATE 10/10/13	TITLE ST-1200 LINE SPRING RECEPTACLE 1219-D3***-Z3CT		
FINISH: NOTED			CHK. Frank Basile	DATE 10/10/13			SIZE A FSCM NO. 72794 DWG. NO. C1219-D3 REV. A
THE FASTENER PARTS SHOWN IN THIS PRINT ARE PROPRIETARY ARTICLES TO WHICH DFCI SOLUTIONS INC., RETAINS THE EXCLUSIVE RIGHTS OF MANUFACTURE, USE AND SALE. THE PRINT OR DRAWING IS SUBMITTED IN CONFIDENCE AND DOES NOT CONVEY A LICENSE OR PERMISSION TO MANUFACTURE THE FASTENER OR FASTENER PARTS. (C) COPYRIGHT 2009, DFCI SOLUTIONS INC. ALL RIGHTS RESERVED.			ENG. Peter Altkorn	DATE 10/10/13	SCALE: NTS WEIGHT: .0010 LBS. SHEET 1 OF 1		
			MFG. Rashm Lubman	DATE 10/10/13			
		NEXT ASSY	USED ON	G.C. Peter Altkorn	DATE 10/10/13		
		APPLICATION BLOCK		SALES.	DATE		