

REVISIONS			
SYS	DESCRIPTION	DATE	APPROV
E	PER ECN 1168	4/13/2011	

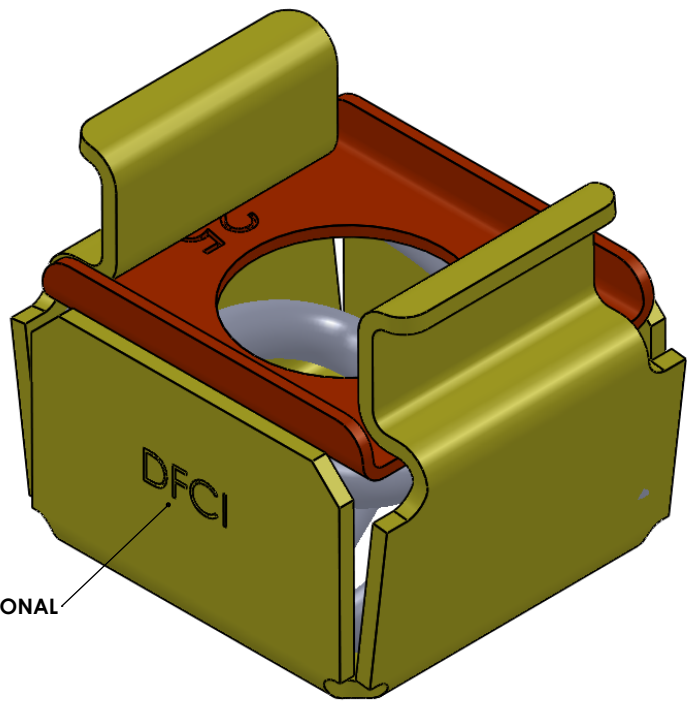
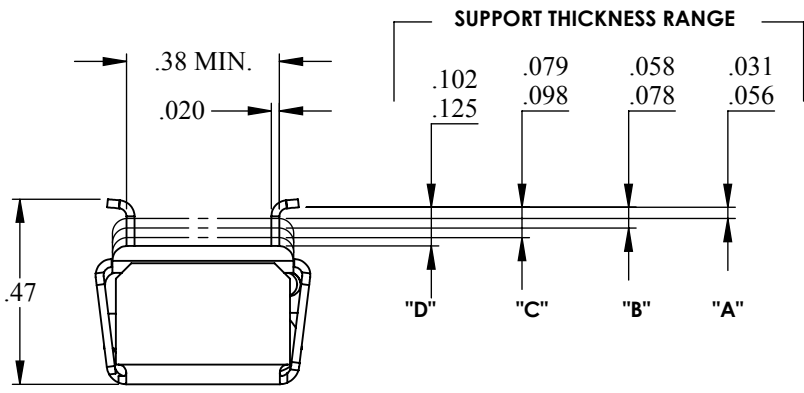
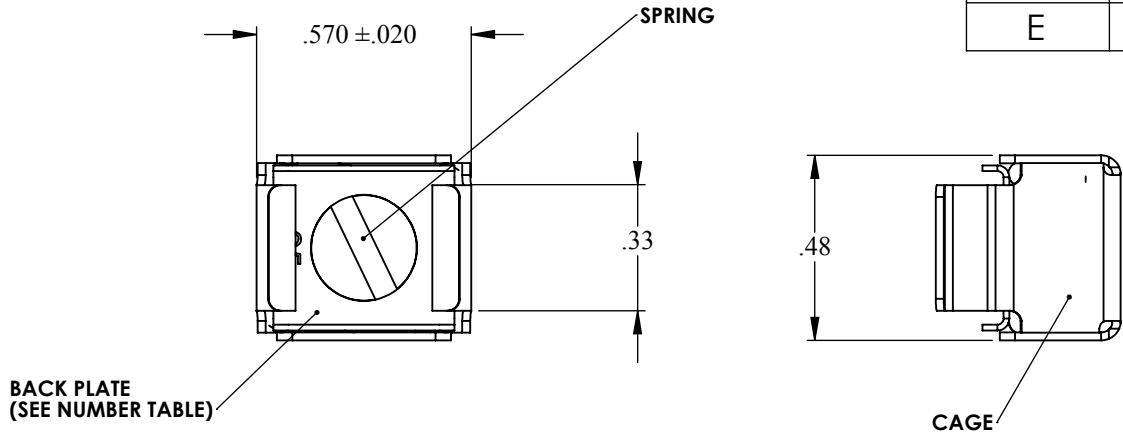

UNCONTROLLED

MATERIAL:	PER NOTE 3
HEAT TREAT:	PER NOTE 3
FINISH:	PER NOTE 1
<small>THE FASTENER PARTS SHOWN IN THIS PRINT ARE PROPRIETARY ARTICLES TO WHICH DFCI SOLUTIONS INC., RETAINS THE EXCLUSIVE RIGHTS OF MANUFACTURE, USE AND SALE. THE PRINT OR DRAWING IS SUBMITTED IN CONFIDENCE AND DOES NOT CONVEY A LICENSE OR PERMISSION TO MANUFACTURE THE FASTENER OR FASTENER PARTS.</small>	
<small>(C) COPYRIGHT 2009, DFCI SOLUTIONS INC. ALL RIGHTS RESERVED.</small>	

TOLERANCES ON DIMENSIONS UNLESS OTHERWISE SPECIFIED			
X* = ±2*		.XX = ±.015	
X/X = ±1/32		.XXX = ±.010	
MACHINE FINISH = .125			
PART NO.	SEE SHEET 2 OF 2	DRN	Frank Basile
		DATE	4/13/11
		CHK.	Frank Basile
		DATE	4/13/11
		ENG.	Robert Altkorn
		DATE	4/13/11
		MFG.	Christopher J. Parnis
		DATE	4/13/11
		G.C.	Robert Altkorn
		DATE	4/13/11
NEXT ASSY	USED ON	SALES.	
		DATE	

		DFCI SOLUTIONS INC. 425 UNION BOULEVARD. WEST ISLIP, NEW YORK 11795	
TITLE			
ST-1200 RECEPTACLE ASSEMBLY 1219-QC4**-Z3CT			
SIZE	FSCM NO.	DWG. NO.	REV.
A	72794	C1219-QC	E
SCALE: NTS		WEIGHT: .0077 LBS.	SHEET 1 OF 2

REVISIONS			
SYS	DESCRIPTION	DATE	APPROV
E	PER ECN 1168	4/13/2011	

NOTES:

- FINISH:**
ZINC PLATE PER ASTM-B-633, TYPE III, SC2, CLEAR TRIVALENT CHROMATE WITH SEALER.
THE ABOVE MENTIONED FINISH WILL BE SUPPLIED AS THE STANDARD FINISH, UPON DEPLETION OF EXISTING STOCK WHICH ARE FINISHED AS FOLLOWS: ZINC PLATE PER ASTM-B-633, TYPE II, SC2 YELLOW CHROMATE.
- FOR THE APPLICATION OF ALTERNATE FINISHES, REMOVE THE SUFFIX -Z3CT FROM THE PART NUMBER AND ADD THE REQUIRED FINISH SUFFIX TO THE PART NUMBER. EXAMPLE, FOR YELLOW ZINC TRIVALENT CHROMATE THE PART NUMBER WOULD BE 1219-QC416-Z3YT
- MATERIALS:**
BACK PLATE AND CAGE: STEEL PER A.I.S.I. 1060 - 1075, HEAT TREATED TO SPRING TEMPER.
SPRING: MUSIC WIRE PER ASTM-A-228
- PLEASE VISIT WWW.DFCIS.COM/C1219-QC FOR A LIST OF AVAILABLE FINISHES.

ASSEMBLY PART NUMBER	REF.	BACK PLATE NUMBER
1219-QC416-Z3CT	"A"	16
1219-QC420-Z3CT	"B"	20
1219-QC425-Z3CT	"C"	25
1219-QC430-Z3CT	"D"	30

UNCONTROLLED

MATERIAL: PER NOTE 3	TOLERANCES ON DIMENSIONS UNLESS OTHERWISE SPECIFIED X* = ±2° .XX = ±.015 X/X = ±1/32 .XXX = ±.010 MACHINE FINISH = .125			DFCI SOLUTIONS INC. 425 UNION BOULEVARD. WEST ISLIP, NEW YORK 11795			
HEAT TREAT: PER NOTE 3	PART NO. SEE CHART	DRN <i>Frank Basile</i> DATE 4/13/11	CHK. <i>Frank Basile</i> DATE 4/13/11				TITLE ST-1200 RECEPTACLE ASSEMBLY 1219-QC4**-Z3CT
FINISH: PER NOTE 1		ENG. <i>Robert Altkorn</i> DATE 4/13/11	MFG. <i>Charles J. Piniol</i> DATE 4/13/11	SIZE A	FSCM NO. 72794	DWG. NO. C1219-QC	REV. E
THE FASTENER PARTS SHOWN IN THIS PRINT ARE PROPRIETARY ARTICLES TO WHICH DFCI SOLUTIONS INC., RETAINS THE EXCLUSIVE RIGHTS OF MANUFACTURE, USE AND SALE. THE PRINT OR DRAWING IS SUBMITTED IN CONFIDENCE AND DOES NOT CONVEY A LICENSE OR PERMISSION TO MANUFACTURE THE FASTENER OR FASTENER PARTS. (C) COPYRIGHT 2009, DFCI SOLUTIONS INC. ALL RIGHTS RESERVED.	NEXT ASSY	USED ON	G.C. <i>Robert Altkorn</i> DATE 4/13/11	SCALE: NTS	WEIGHT: .0077 LBS.	SHEET 2 OF 2	