

REVISIONS			
SYS	DESCRIPTION	DATE	APPROV
B	PER ECN 1168	01/12/09	

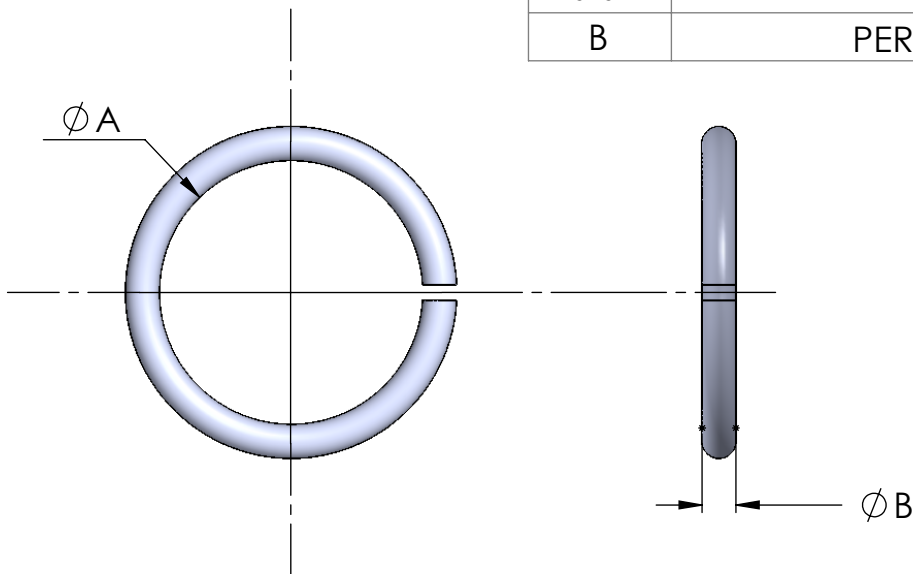
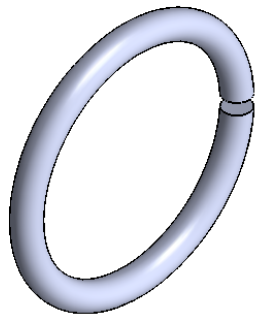

UNCONTROLLED

PART NO.	A	B <sup>+0.002</sup>
1219-R3-SS	.172 <sup>+0.000</sup> <sub>-.010</sub>	.022
1219-R35-SS	.202 <sup>+0.000</sup> <sub>-.012</sub>	.022
1219-R4-SS	.230 <sup>+0.000</sup> <sub>-.014</sub>	.029
1219-R5-SS	.288 <sup>+0.000</sup> <sub>-.017</sub>	.035
1219-R6-SS	.345 <sup>+0.000</sup> <sub>-.021</sub>	.043
1219-R7-SS	.402 <sup>+0.000</sup> <sub>-.020</sub>	.051

MATERIAL:	TYPE 302 ST. STEEL
HEAT TREAT:	NONE
FINISH:	CLEAN AND FREE OF BURRS.
<small>THE FASTENER PARTS SHOWN IN THIS PRINT ARE PROPERTY ARTICLES TO WHICH DFCI SOLUTIONS INC., RETAINS THE EXCLUSIVE RIGHTS OF MANUFACTURE, USE AND SALE. THE PRINT OF DRAWING IS SUBMITTED IN CONFIDENCE AND DOES NOT CONVEY A LICENCE OR PERMISSION TO MANUFACTURE THE FASTENER OR FASTENER PARTS.</small>	
<small>(C) COPYRIGHT 2009, DFCI SOLUTIONS INC. ALL RIGHTS RESERVED.</small>	

TOLERANCES ON DIMENSIONS UNLESS OTHERWISE SPECIFIED X* = ±2° .XX = ±.015 CONCENTRICITY F.I.M. .005 X/X = ±1/32 .XXX = ±.010 MACHINE FINISH = 125			
PART NO.	DRN	DATE	
	W. Zhindon	01/13/10	
	CHK. Frank Basile	DATE 01/15/10	
	ENG. Robert Altkorn	DATE 01/15/10	
	MFG. Bill Velazquez	DATE 01/19/10	
	G.C. Robert Altkorn	DATE 01/15/10	
NEXT ASSY	USED ON	SALES.	DATE
APPLICATION BLOCK			

**DFCI SOLUTIONS INC.**  
 425 UNION BOULEVARD.  
 WEST ISLIP, NEW YORK 11795

TITLE		ST-1200 RETAINING RING LINE, 1219-Rx-SS.	
SIZE	FSCM NO.	DWG. NO.	REV.
A	72794	C1219-R	B
SCALE: NTS		WEIGHT:	SHEET 1 OF 1