

# UNCONTROLLED

REVISIONS			
SYS	DESCRIPTION	DATE	APPROV
D	PER ECN 1189	06/07/10	F.B

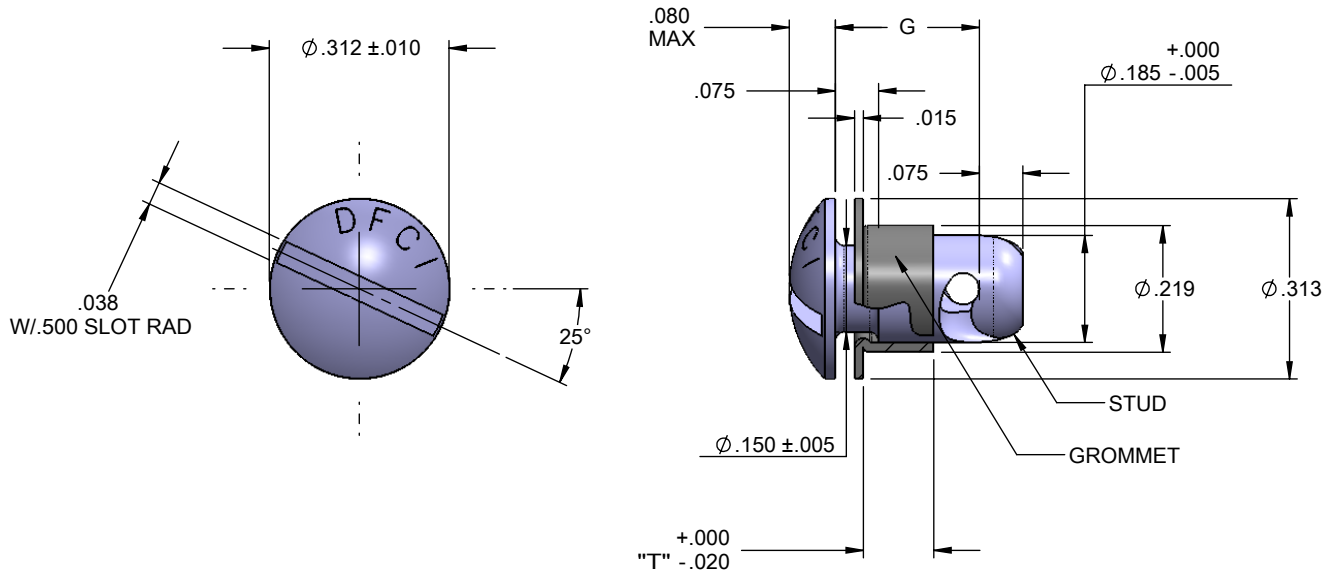
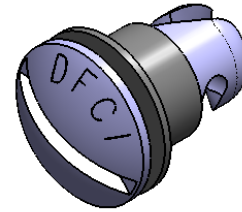

MATERIAL:	NOTED
HEAT TREAT:	NOTED
FINISH:	NOTED
<small>THE FASTENER PARTS SHOWN IN THIS PRINT ARE PROPRIETARY ARTICLES TO WHICH DFCI SOLUTIONS INC., RETAINS THE EXCLUSIVE RIGHTS OF MANUFACTURE, USE AND SALE. THE PRINT OR DRAWING IS SUBMITTED IN CONFIDENCE AND DOES NOT CONVEY A LICENSE OR PERMISSION TO MANUFACTURE THE FASTENER OR FASTENER PARTS.</small>	
<small>(C) COPYRIGHT 2009, DFCI SOLUTIONS INC. ALL RIGHTS RESERVED.</small>	

TOLERANCES ON DIMENSIONS UNLESS OTHERWISE SPECIFIED			
X* = ±2°	.XX = ±.015	MACHINE FINISH = .125 $\sqrt{\text{ }}$	
X/X = ±1/32	.XXX = ±.010		
PART NO.	DRN	DATE	
	W. Zhindon	06/08/10	
	CHK. Frank Basile	DATE 06/08/10	
	ENG. [Signature]	DATE 06/15/10	
	MFG. [Signature]	DATE 06/15/10	
NEXT ASSY	USED ON	Q.C. [Signature]	DATE 06/15/10
APPLICATION BLOCK		SALES.	DATE

**DFCI SOLUTIONS INC.**  
 425 UNION BOULEVARD.  
 WEST ISLIP, NEW YORK 11795

TITLE			
ST-1200 STUD + GRUMMET ASSY. 121J-3xxTxxx-Z3CT			
SIZE	FSCM NO.	DWG. NO.	REV
A	72794	C121J-3-T	D
SCALE: NTS		WEIGHT:	SHEET 1 OF 2

# UNCONTROLLED

REVISIONS			
SYS	DESCRIPTION	DATE	APPROV
D	PER ECN 1189	06/07/10	F.B

NOTES:

- MATERIAL  
STUD: PER A.I.S.I 8620, 10B21 STEEL  
GROMMET : 3003-H14 OR 1100-H14
- HEAT TREATMENT:  
STEEL STUD: ROCKWELL C27-33
- FINISH STEEL STUD:  
ZINC PLATE PER ASTM-B-633, TYPE III, SC 2,  
CLEAR TRIVALENT CHROMATE WITH SEALER.  
(RoHS COMPLIANT) FINISH SUFFIX: -Z3CT
- FOR THE APPLICATION OF ALTERNATIVE  
FINISHES, REMOVE SUFFIX -Z3CT FROM THE  
PART NO. AND ADD THE REQUIRED FINISH TO  
THE PART NO. SUFFIX. "EXAMPLE FOR YELLOW  
ZINC TRIVALENT CHROMATE FINISH THE PART  
NO. IS 121J-325T175-Z3YT"
- PLEASE VISIT WWW.DFCIS.COM/C121J-3-T FOR A  
LIST OF AVAILABLE FINISHES.

ASSY PART NO	STUD P/N	GROMMET P/N	T DIM	G DIM	U DIM
121J-330T130-Z3CT	121J-330-Z3CT	127S-A3T130	.130	.300	.100
121J-330T150-Z3CT	121J-330-Z3CT	127S-A3T150	.150	.300	.100
121J-345T250-Z3CT	121J-345-Z3CT	127S-A3T250	.250	.450	.225
121J-355T300-Z3CT	121J-355-Z3CT	127S-A3T300	.300	.550	.275
121J-375T425-Z3CT	121J-375-Z3CT	127S-A3T425	.425	.750	.400
121J-370T575-Z3CT	121J-370-Z3CT	127S-A3T575	.575	.700	.350

MATERIAL: NOTED	TOLERANCES ON DIMENSIONS UNLESS OTHERWISE SPECIFIED X* = ±2* .XX = ±.015 X/X = ±1/32 .XXX = ±.010 MACHINE FINISH = .125 <input checked="" type="checkbox"/>			 <b>DFCI SOLUTIONS INC.</b> 425 UNION BOULEVARD. WEST ISLIP, NEW YORK 11795
HEAT TREAT: NOTED	PART NO.	DRN <i>W. Zhindon</i>	DATE 06/08/10	
FINISH: NOTED		CHK. <i>Frank Basile</i>	DATE 06/08/10	
THE FASTENER PARTS SHOWN IN THIS PRINT ARE PROPERTY ARTICLES TO WHICH DFCI SOLUTIONS INC., RETAINS THE EXCLUSIVE RIGHTS OF MANUFACTURE, USE AND SALE. THE PRINT OR DRAWING IS SUBMITTED IN CONFIDENCE AND DOES NOT CONVEY A LICENSE OR PERMISSION TO MANUFACTURE THE FASTENER OR FASTENER PARTS.  (C) COPYRIGHT 2009, DFCI SOLUTIONS INC. ALL RIGHTS RESERVED.		ENG. <i>Bill Velazquez</i>	DATE 06/15/10	
		MFG. <i>Bill Velazquez</i>	DATE 06/15/10	
	NEXT ASSY	USED ON	Q.C. <i>Bill Velazquez</i>	DATE 06/15/10
	APPLICATION BLOCK	SALES.	DATE	TITLE <b>ST-1200 STUD + GRUMMET ASSY. 121J-3xxTxxx-Z3CT</b>
				SIZE FSCM NO DWG. NO. REV <b>A 72794 C121J-3-T D</b>
				SCALE: NTS WEIGHT: SHEET 2 OF 2