

UNCONTROLLED

REVISIONS			
SYM	DESCRIPTION	DATE	APPROV
A	NITIAL RELEASE PER ECN 845.	11-10-08	<i>FB</i>

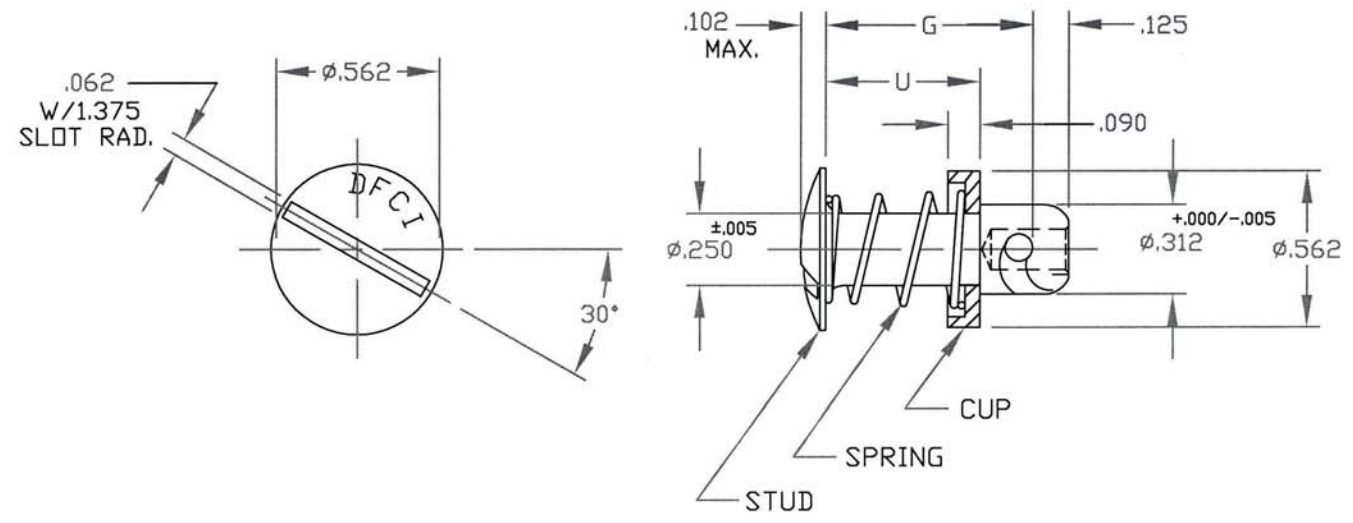

FOR PART NO. REFER TO SHEET 2 of 2.

MAT'L PER NOTE 1.	TOLERANCES ON DIMENSIONS UNLESS OTHERWISE SPECIFIED X* = ±2* .XX = ± .015 X/X = ±1/32 .XXX = ± .010 MACHINE FINISH 125		DFCI SOLUTIONS INC. 425 UNION BOULEVARD WEST ISLIP, NEW YORK 11795	
HEAT TREAT PER NOTE 2.	PART NO.	DRN <i>S. Francis</i>	DATE 11-10-08	TITLE ST-1200 SPEC. U STUD ASSY.
FINISH PER NOTE 3.		CHK <i>F. Basil</i>	DATE 11-11-08	
		ENG <i>B. Hildner</i>	DATE 11/20/08	121J-5xxBxxx-SE-Z3CT.
		MFG <i>Bill H</i>	DATE 11-10-08	
	NEXT ASSY	USED ON	DATE 11/20/08	SIZE A
APPLICATION BLOCK		SALES	DATE	FSCM NO 72794
				DWG. NO. C121J-5BSE
				REV. A
				SCALE NTS
				WT.
				SHEET 1 OF 2

DATE: 07/01/06 FORM: DRAWING

UNCONTROLLED

REVISIONS			
SYM	DESCRIPTION	DATE	APPROV
A	INITIAL RELEASE PER ECN 845.	11-10-08	<i>FB</i>

NOTES:

- MATERIAL:
STUD: PER A.I.S.I 8620, STEEL OR TYPE 303 ST. STEEL.
SPRING: ST. STEEL, .022 DIA. TYPE 302/316, SPRING TEMPER.
CUP: ACETAL CELCON.
- HEAT TREAT: ROCKWELL C27- 33. (STEEL STUD ONLY)
STAINLESS STEEL STUD IS NOT HEAT TREATED.
- FINISH STEEL STUD ONLY:
ZINC PLATE PER ASTM-B-633, TYPE III, SC 2, CLEAR TRIVALENT CHROMATE WITH SEALER. (ROHS COMPLIANT) FINISH SUFFIX: -Z3CT
- FOR THE APPLICATION OF ALTERNATIVE FINISHES, REMOVE SUFFIX -Z3CT FROM THE PART NO. AND ADD THE REQUIRED FINISH TO THE PART NO. SUFFIX,
*EXAMPLE FOR BLACK ZINC TRIVALENT CHROMATE FINISH, THE PART IS 121J-550B325-SE-Z3BT.
- PLEASE VISIT WWW.DFCIS.COM/C121J-5BSE FOR A LIST OF AVAILABLE FINISHES.

PART No.	G	U	WEIGHT (LBS.)
121J-550B325-SE-Z3CT (STEEL)	.500	.325	.0122
121J-5110B900-SE-Z3CT (STEEL)	1.100	.900	.0210
121J-5110B900-SE-SS (STAINLESS STEEL)			

MAT'L PER NOTE 1.	TOLERANCES ON DIMENSIONS UNLESS OTHERWISE SPECIFIED X* = ±2* .XX = ±.015 X/X = ±1/32 .XXX = ±.010 MACHINE FINISH 125T		 DFCI SOLUTIONS INC. 425 UNION BOULEVARD WEST ISLIP, NEW YORK 11795		
HEAT TREAT PER NOTE 2.	PART NO.	DRN <i>S. F. RAY</i>			DATE 11-10-08
FINISH PER NOTE 3.		CHK <i>F. Basile</i>	DATE 11-11-08	TITLE 1200 SPEC. U STUD ASSY. 121J-5xxBxxx-SE-Z3CT.	
		ENG <i>B. Hildebrand</i>	DATE 11-20-08		
		MFG <i>[Signature]</i>	DATE 11-20-08	SIZE A	
	NEXT ASSY	USED ON	DATE 11-20-08	FSCM NO 72794	
	APPLICATION BLOCK	SALES	DATE	DWG. NO. C121J-5BSE	
			SCALE NTS	WT.	
			SHEET 2 OF 2		
		REV. A			

DATE: 07/01/06 FORM: DRAWING