

REVISIONS			
SYS	DESCRIPTION	DATE	APPROV
B	PER ECN 1168 & 1250	08/08/14	

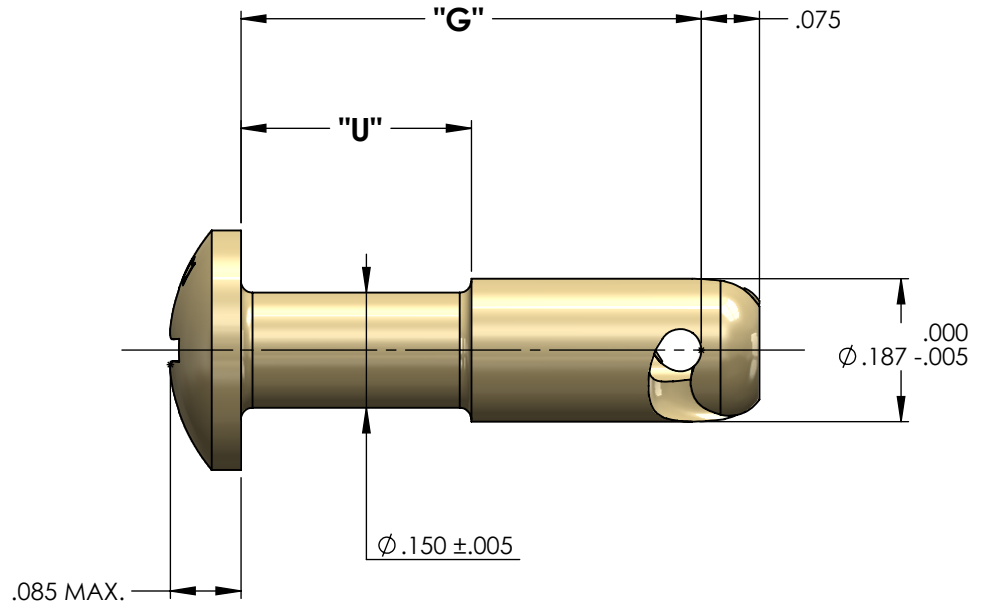
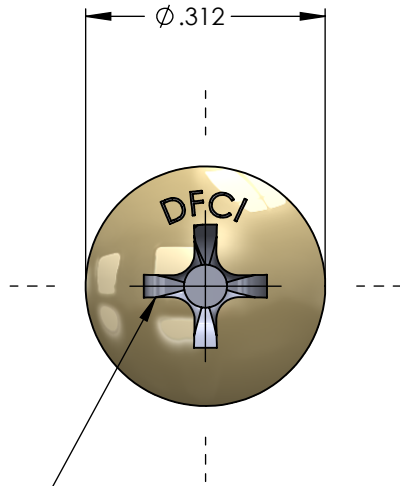
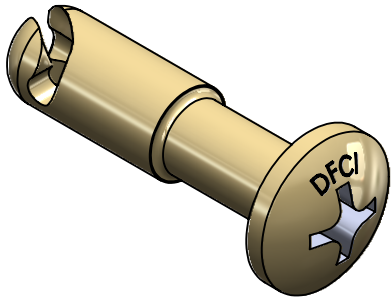

#2 PHILLIPS RECESS FLOW OUT ON ALL FOUR ENDS PERMISSIBLE.

UNCONTROLLED

MATERIAL:	A.I.S.I 8620 OR 10B21 STEEL SEE NOTE 3 FOR TYPE 303 STAINLESS STEEL
HEAT TREAT:	SEE NOTE 2
FINISH:	SEE NOTE 1
<small>THE FASTENER PARTS SHOWN IN THIS PRINT ARE PROPRIETARY ARTICLES TO WHICH DFCI SOLUTIONS INC., RETAINS THE EXCLUSIVE RIGHTS OF MANUFACTURE, USE AND SALE. THE PRINT OR DRAWING IS SUBMITTED IN CONFIDENCE AND DOES NOT CONVEY A LICENSE OR PERMISSION TO MANUFACTURE THE FASTENER OR FASTENER PARTS.</small>	
<small>(C) COPYRIGHT 2009, DFCI SOLUTIONS INC. ALL RIGHTS RESERVED.</small>	

TOLERANCES ON DIMENSIONS UNLESS OTHERWISE SPECIFIED			
$X^\circ = \pm 2^\circ$	$.XX = \pm .015$	MACHINE FINISH = .125	
$X/X = \pm 1/32$	$.XXX = \pm .010$		
PART NO.	SEE TABLE	DRN	DATE
		Frank Basile	08/08/14
		CHK. Frank Basile	DATE 08/08/14
		ENG. <i>[Signature]</i>	DATE 08/08/14
		MFG. <i>[Signature]</i>	DATE 08/08/14
		Q.C. <i>[Signature]</i>	DATE 08/08/14
NEXT ASSY	USED ON	SALES.	DATE



DFCI SOLUTIONS INC.
425 UNION BOULEVARD.
WEST ISLIP, NEW YORK 11795

TITLE				ST-1200 PHILLIPS RECESS HEAD STUD 121J-P3**-Z3CT	
SIZE	FSCM NO.	DWG. NO.		REV.	
A	72794	C121J-P3		B	
SCALE: NTS			WEIGHT:		SHEET 1 OF 2

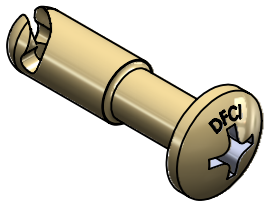

UNCONTROLLED

REVISIONS			
SYS	DESCRIPTION	DATE	APPROV
B	PER ECN 1168 & 1250	08/08/14	

PART NUMBER	"G"	"U"
121J-P325-Z3CT	.250	.075
121J-P330-Z3CT	.300	.100
121J-P335-Z3CT	.350	.150
121J-P340-Z3CT	.400	.200
121J-P345-Z3CT	.450	.225
121J-P350-Z3CT	.500	.250
121J-P355-Z3CT	.550	.275
121J-P360-Z3CT	.600	.300
121J-P365-Z3CT	.650	.350
121J-P370-Z3CT	.700	
121J-P375-Z3CT	.750	.400
121J-P380-Z3CT	.800	
121J-P390-Z3CT	.900	.500
121J-P3100-Z3CT	1.000	
121J-P3110-Z3CT	1.100	
121J-P3120-Z3CT	1.120	
121J-P3130-Z3CT	1.130	
121J-P3140-Z3CT	1.140	
121J-P3150-Z3CT	1.150	

- NOTES:**
- FINISH:**
ZINC PLATE PER ASTM-B-633, TYPE III, SC2, CLEAR TRIVALENT CHROMATE WITH SEALER. (RoHS COMPLIANT) FINISH SUFFIX -Z3CT

THE ABOVE MENTIONED FINISH WILL BE SUPPLIED AS THE STANDARD FINISH UPON DEPLETION OF EXISTING STOCK WHICH ARE FINISHED AS FOLLOWS: ZINC PLATE PER ASTM-B-633, TYPE III, SC2, CLEAR CHROMATE. FINISH SUFFIX -Z3C
 - HEAT TREATMENT:**
STEEL STUD ONLY: ROCKWELL C30 - 38
 - FOR A STUD MADE FROM TYPE 303 STAINLESS STEEL, REMOVE SUFFIX -Z3CT FROM THE PART NUMBER AND ADD -SS**
EXAMPLE: 121J-P360-SS
 - FOR THE APPLICATION OF AN ALTERNATE FINISH, REMOVE THE SUFFIX -Z3CT FROM THE PART NUMBER AND ADD THE REQUIRED FINISH SUFFIX.**
EXAMPLE: FOR YELLOW ZINC TRIVALENT CHROMATE FINISH, THE PART NUMBER WOULD BE 121J-P360-Z3YT
 - PLEASE VISIT WWW.DFCIS.COM/C121J-P3 FOR A LIST OF AVAILABLE FINISHES.**

MATERIAL: A.I.S.I 8620 OR 10B21 STEEL SEE NOTE 3 FOR TYPE 303 STAINLESS STEEL		TOLERANCES ON DIMENSIONS UNLESS OTHERWISE SPECIFIED X* = ±2* .XX = ±.015 X/X = ±1/32 .XXX = ±.010 MACHINE FINISH = .125		 DFCI SOLUTIONS INC. 425 UNION BOULEVARD. WEST ISLIP, NEW YORK 11795	
HEAT TREAT: SEE NOTE 2		PART NO. SEE TABLE			
FINISH: SEE NOTE 1				CHK: <i>Frank Basile</i> DATE: 08/08/14	TITLE: ST-1200 PHILLIPS RECESS HEAD STUD 121J-P3**-Z3CT
THE FASTENER PARTS SHOWN IN THIS PRINT ARE PROPRIETARY ARTICLES TO WHICH DFCI SOLUTIONS INC., RETAINS THE EXCLUSIVE RIGHTS OF MANUFACTURE, USE AND SALE. THE PRINT OR DRAWING IS SUBMITTED IN CONFIDENCE AND DOES NOT CONVEY A LICENSE OR PERMISSION TO MANUFACTURE THE FASTENER OR FASTENER PARTS. (C) COPYRIGHT 2009, DFCI SOLUTIONS INC. ALL RIGHTS RESERVED.				ENG: <i>Robert Alford</i> DATE: 08/08/14	
				MFG: <i>Rashm Lubman</i> DATE: 08/08/14	
		NEXT ASSY USED ON		G.C: <i>Robert Alford</i> DATE: 08/08/14	
APPLICATION BLOCK		SALES: DATE: 08/08/14		SIZE: A FSCM NO: 72794	DWG. NO. C121J-P3
				SCALE: NTS	REV. B
				WEIGHT:	SHEET 2 OF 2