

UNCONTROLLED

C1224-936 REV. A

REVISIONS			
SYM	DESCRIPTION	DATE	APPROV
A	INITIAL RELEASE PER ECN 845	12-1-08	FB

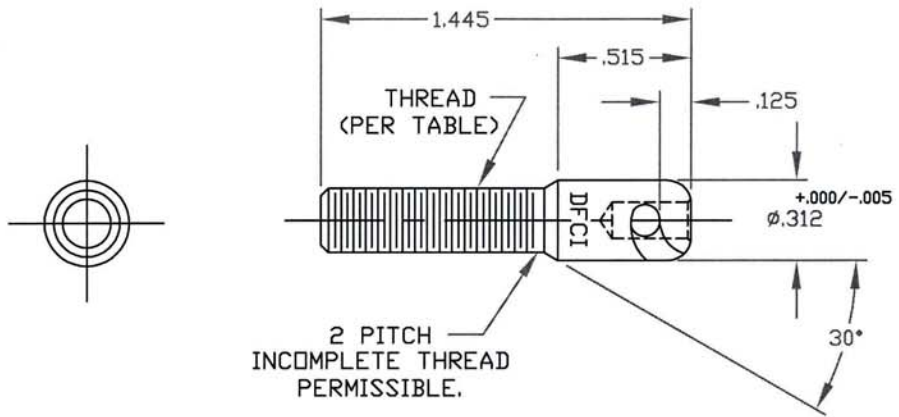

PART No.	THREAD	WEIGHT	MATERIAL
1224-936-Z3CT	1/4-20 UNC-2A	.0174	PER A.I.S.I 8620 STEEL.
1224-936A-Z3CT	5-16-18 UNC-2A	.0229	
1224-936C-Z3CT	1/4-28 UNF-2A	.0174	
1224-936D-Z3CT	10-32 UNF-2A	.014	
1224-936-SS	1/4-20 UNC-2A	.0174	TYPE 303 ST. STEEL.
1224-936A-SS	5-16-18 UNC-2A	.0229	
1224-936C-SS	1/4-28 UNF-2A	.0174	
1224-936D-SS	10-32 UNF-2A	.014	

NOTES:

- HARDNESS: (ROCKWELL C30-38) APPLIES ONLY TO STEEL STUD, STAINLESS STEEL STUD IS NOT HARDENED.
- FINISH STEEL STUD:
ZINC PLATE PER ASTM-B-633, TYPE III, SC 2, CLEAR TRIVALENT CHROMATE WITH SEALER. (RoHS COMPLIANT) FINISH SUFFIX: -Z3CT
THE ABOVE MENTIONED FINISH WILL BE SUPPLIED AS THE STANDARD FINISH, UPON DEPLETION OF EXISTING STOCK WHICH ARE FINISHED AS FOLLOW: ZINC PLATE PER ASTM-B-633, TYPE III, SC 2, CLEAR CHROMATE. FINISH SUFFIX -Z3C.

MAT'L AS NOTED.		TOLERANCES ON DIMENSIONS UNLESS OTHERWISE SPECIFIED X* = ±2* .XX = ±.015 X/X = ±1/32 .XXX = ±.010		MACHINE FINISH 125/		DFCI SOLUTIONS INC. 425 UNION BOULEVARD WEST ISLIP, NEW YORK 11795	
HEAT TREAT PER NOTE 1.		PART NO.	DRN S. FRANCO	DATE 12-1-08	TITLE 1200 LINE, ENDS FASTENER, 1224-936x-Z3CT.		
FINISH PER NOTE 2.			CHK F. Basile	DATE 12-2-08	SIZE A	FSCM NO 72794	DWG. NO. C1224-936
THE FASTENER PARTS SHOWN IN THIS PRINT ARE PROPRIETARY ARTICLES TO WHICH DFCI SOLUTIONS INC. RETAINS THE EXCLUSIVE RIGHTS OF MANUFACTURE, USE AND SALE. THE PRINT OR DRAWING IS SUBMITTED IN CONFIDENCE AND DOES NOT CONVEY A LICENSE OR PERMISSION TO MANUFACTURE THE FASTENER OR FASTENER PARTS.		NEXT ASSY	USED ON	DATE 12/2/08	REV. A		
© COPYRIGHT 2003, DFCI SOLUTIONS INC. ALL RIGHTS RESERVED. DATE: 07/01/06 FORM: DRAWING		APPLICATION BLOCK	SALES	DATE 12/2/08	SCALE NTS	WT.	SHEET 1 OF 1