

UNCONTROLLED

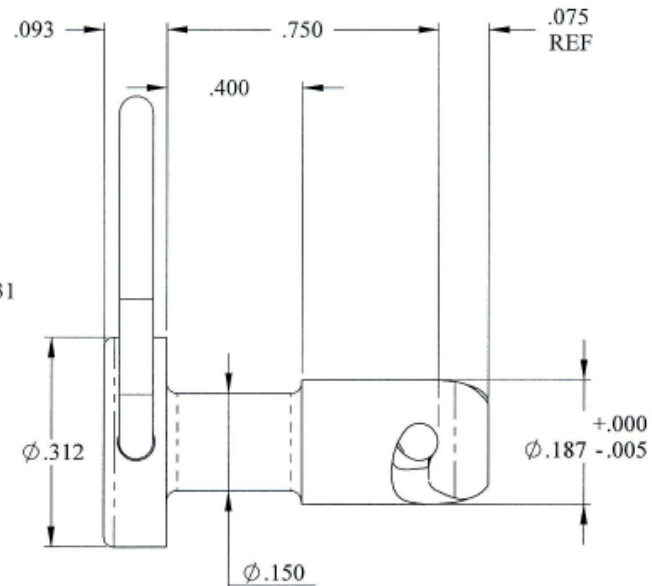
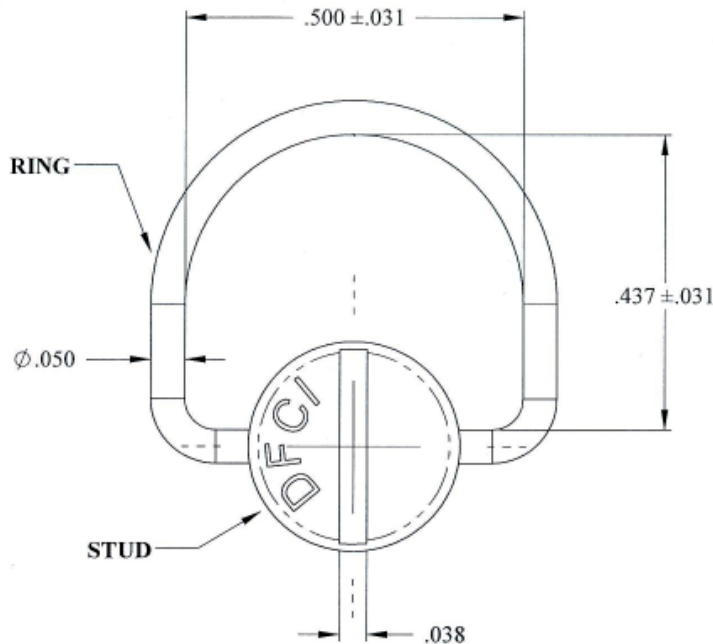

REVISIONS			
SYS	DESCRIPTION	DATE	APPROV
E	PER ECN 1168	11-23-09	<i>FB</i>

MATERIAL:	PER NOTE 4.
HEAT TREAT:	PER NOTE 5
FINISH:	PER NOTE 1
<small>THE FASTENER PARTS SHOWN IN THIS PRINT ARE PROPERTY ARTICLES TO WHICH DFCI SOLUTIONS INC., RETAINS THE EXCLUSIVE RIGHTS OF MANUFACTURE, USE AND SALE. THE PRINT OF DRAWING IS SUBMITTED IN CONFIDENCE AND DOES NOT CONVEY A LICENSE OR PERMISSION TO MANUFACTURE THE FASTENER OR FASTENER PARTS.</small>	
<small>(C) COPYRIGHT 2009, DFCI SOLUTIONS INC. ALL RIGHTS RESERVED.</small>	

TOLERANCES ON DIMENSIONS UNLESS OTHERWISE SPECIFIED	
X' = ±2"	MACHINE FINISH = 125/7
XX = ±1/32	.XX = ±.015
XXX = ±.010	.XXX = ±.010
PART NO.	DATE
	<i>W. Zhindón</i> 11-24-09
DRN	DATE
	<i>F. Basile</i> 11-24-09
CHK	DATE
	<i>B. Hildbrun</i> 11-24-09
ENR	DATE
	<i>B. Hildbrun</i> 11-24-09
DES	DATE
	<i>B. Hildbrun</i> 11-24-09
MFG	DATE
	<i>B. Hildbrun</i> 11-24-09
Q. C.	DATE
	<i>B. Hildbrun</i> 11-24-09
SALES	DATE
	<i>B. Hildbrun</i> 11-24-09
NEXT ASSY	USED ON
APPLICATION BLOCK	



DFCI SOLUTIONS INC.
 425 UNION BOULEVARD,
 WEST ISLIP, NEW YORK 11795

TITLE		ST-1200 RING HD. STUD 122J-R375A90-Z3BT.	
SIZE	#SCM NO	DWG. NO.	REV.
A	72794	C122J-R3-241812	E
SCALE: NTS		WEIGHT:	SHEET 1 OF 2

DATE: 11-11-09 FORM: DRAWING

The parts shown in this print are proprietary articles to which DFCI Solutions, Inc. retains the exclusive rights of manufacture, use and sale. The print or drawing is submitted in confidence and does not convey a license or permission to manufacture the parts. Copyright © 2009 by DFCI Solutions, Inc. All rights reserved.

UNCONTROLLED



REVISIONS			
SYS	DESCRIPTION	DATE	APPROV
E	PER ECN 1168	11-23-09	ZB

<p align="center">PART NO. (STEEL STUD ASSY) 122J-R375A90-Z3BT</p>

- NOTES:
- FINISH:
ZINC PLATE PER ASTM-B-633, TYPE II, SC 2,
BLACK TRIVALENT CHROMATE WITH SEALER.
(RoHS COMPLIANT) FINISH SUFFIX: -Z3BT
 - FOR THE APPLICATION OF ALTERNATIVE
FINISHES, REMOVE SUFFIX -Z3BT FROM THE
PART NO. AND ADD THE REQUIRED FINISH TO
THE PART NO. SUFFIX.

EXAMPLE: FOR ZINC BLACK CHROMATE FINISH
THE PART NO. IS 122J-R375A90-Z3B. (FINISH IS
AVAILABLE AT HIGHER COST)
 - PLEASE VISIT WWW.DFCIS.COM/C122J-R3-241812
FOR A LIST OF AVAILABLE FINISHES.
 - MATERIALS:
STUD: PER A.I.S.I 8620 STEEL
RING: HIGH CARBON STEEL WIRE
 - HEAT TREAT:
STUD: ROCKWELL C30-38
RING: ROCKWELL C40-45
 - FOR PART NO. OF STUD ASSY. MADE FROM
TYPE 303 ST STEEL, REMOVE SUFFIX -Z3BT
FROM PART NO. AND ADD "-SS"

EXAMPLE: 122J-R375A90-SS

MATERIAL: PER NOTE 4.	TOLERANCES ON DIMENSIONS UNLESS OTHERWISE SPECIFIED					DFCI SOLUTIONS INC.		
HEAT TREAT: PER NOTE 5	<small>X" = ±2" .XX = ±.015 MACHINE FINISH = 125/7</small> <small>X/XX = ±1/32 .XXX = ±.010</small>					425 UNION BOULEVARD. WEST ISLIP, NEW YORK 11795		
FINISH: PER NOTE 1	PART NO.	DRN	DATE	DATE		TITLE		
<small>THE FASTENER PARTS SHOWN IN THIS PRINT ARE PROPERTY ARTICLES TO WHICH DFCI SOLUTIONS INC. RETAINS THE EXCLUSIVE RIGHTS OF MANUFACTURE, USE AND SALE. THE PRINT OF DRAWING IS SUBMITTED IN CONFIDENCE AND DOES NOT CONVEY A LICENSE OR PERMISSION TO MANUFACTURE THE FASTENER OR FASTENER PARTS.</small> <small>(C) COPYRIGHT 2009, DFCI SOLUTIONS INC. ALL RIGHTS RESERVED.</small>		CHK.	DATE	DATE		ST-1200 RING HD. STUD 122J-R375A90-Z3BT.		
		APP.	DATE	DATE		SIZE	FSCM NO.	DWG. NO.
	NEXT ASSY	USED ON	SALES	DATE		DATE	A	72794
	APPLICATION BLOCK				SCALE: NTS	WEIGHT:	REV. E SHEET 2 OF 2	

DATE: 11-11-09 FORM: DRAWING