

# UNCONTROLLED

REVISIONS			
SYS	DESCRIPTION	DATE	APPROV
A	INITIAL RELEASE	03-27-13	

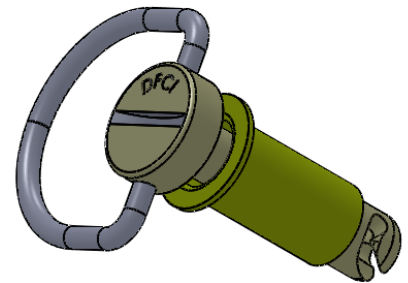
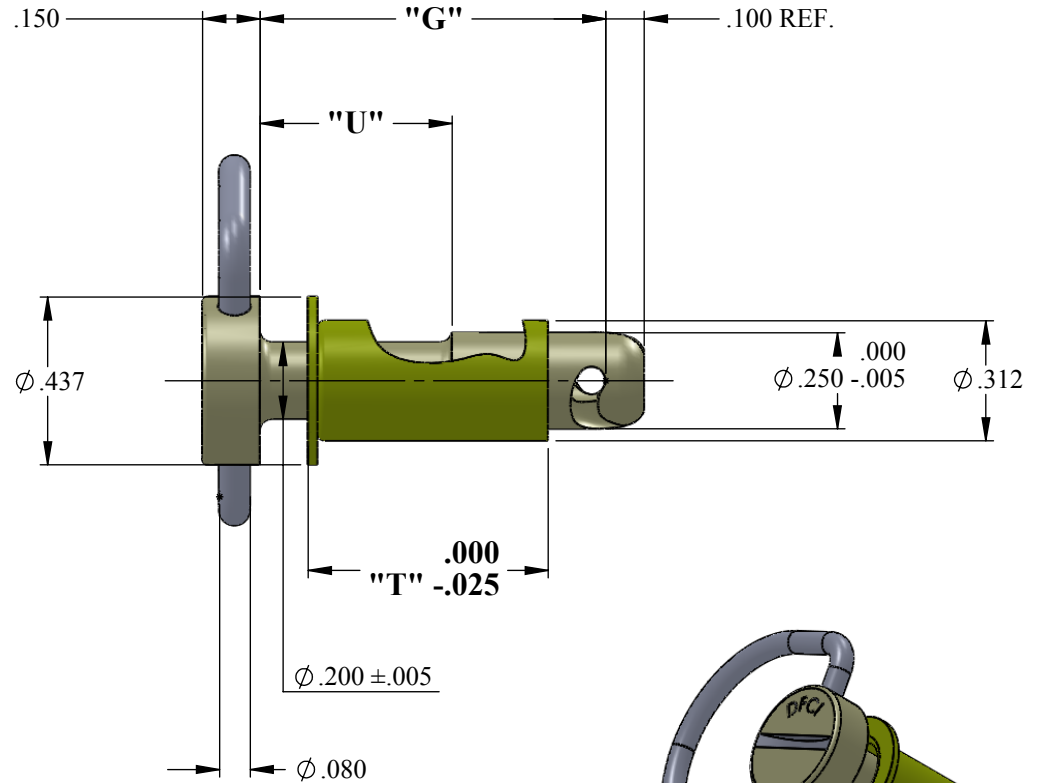
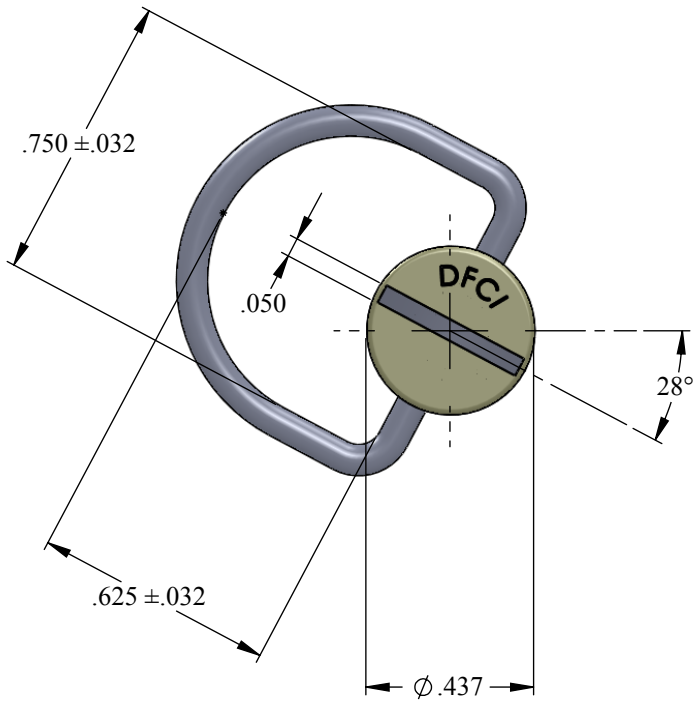

MATERIAL: SEE NOTE 1 ON SHEET 2 OF 2

HEAT TREAT: SEE NOTE 2 ON SHEET 2 OF 2

FINISH: SEE NOTE 3 ON SHEET 2 OF 2

THE FASTENER PARTS SHOWN IN THIS PRINT ARE PROPRIETARY ARTICLES TO WHICH DFCI SOLUTIONS INC., RETAINS THE EXCLUSIVE RIGHTS OF MANUFACTURE, USE AND SALE. THE PRINT OR DRAWING IS SUBMITTED IN CONFIDENCE AND DOES NOT CONVEY A LICENSE OR PERMISSION TO MANUFACTURE THE FASTENER OR FASTENER PARTS.

(C) COPYRIGHT 2009, DFCI SOLUTIONS INC. ALL RIGHTS RESERVED.

TOLERANCES ON DIMENSIONS UNLESS OTHERWISE SPECIFIED

X\* = ±2° .XX = ±0.015  
X/X = ±1/32 .XXX = ±0.010

MACHINE FINISH = 125/7

PART NO.	122J-R4**T***-Z3CT	DRN	Frank Basile	DATE	03-27-13
		CHK.	Frank Basile	DATE	03-27-13
		ENG.	Robert Alldorand	DATE	03-27-13
		MFG.	Rashm Luberman	DATE	03-27-13
		G.C.	Robert Alldorand	DATE	03-27-13
NEXT ASSY	USED ON	SALES.		DATE	



**DFCI SOLUTIONS INC.**

425 UNION BOULEVARD.  
WEST ISLIP, NEW YORK 11795

TITLE: ST-1200 STUD AND GROMMET ASSEMBLY  
122J-R4\*\*T\*\*\*-Z3CT

SIZE: A FSCM NO: 72794 DWG. NO: C122J-R4-T REV. A

SCALE: NTS

WEIGHT:

SHEET 1 OF 2

# UNCONTROLLED

REVISIONS			
SYS	DESCRIPTION	DATE	APPROV
A	INITIAL RELEASE	03-27-13	

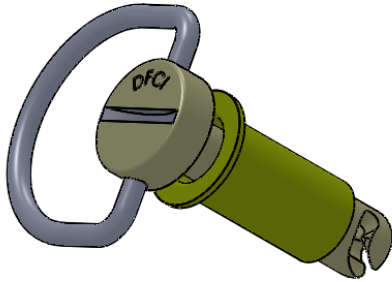

**NOTES:**

- MATERIAL:**  
STUD: A.I.S.I. 8620 OR 10B21 STEEL  
GROMMET: 3003-H14 OR 1100-H14 ALUMINUM
- HEAT TREAT:**  
STUD: ROCKWELL C27-33
- FINISH:**  
STUD: ZINC PLATE PER ASTM-B-633, TYPE III, SC2 CLEAR TRIVALENT CHROMATE WITH SEALER (RoHS COMPLIANT)
- FOR THE APPLICATION OF ALTERNATIVE FINISHES REMOVE SUFFIX -Z3CT FROM THE PART NUMBER AND ADD THE REQUIRED FINISH SUFFIX TO THE PART NUMBER. EXAMPLE, FOR YELLOW ZINC TRIVALENT CHROMATE FINISH THE PART NUMBER WILL BE 122J-R460T250-Z3YT
- PLEASE VISIT [WWW.DFCIS.COM/C122J-R4-T](http://WWW.DFCIS.COM/C122J-R4-T) FOR AN AVAILABLE LIST OF FINISHES.

ASSEMBLY PART NO.	STUD PART NO.	GROMMET PART NO.	"G" DIMENSION	"U" DIMENSION	"T" DIMENSION
122J-R435T150-Z3CT	122J-R435-Z3CT	127S-A4T150	.350	.150	.150
122J-R455T300-Z3CT	122J-R455-Z3CT	127S-A4T300	.550	.275	.300
122J-R460T250-Z3CT	122J-R460-Z3CT	127S-A4T250	.600	.300	.250
122J-R4110T810-Z3CT	122J-R4110-Z3CT	127S-A4T810	1.100	.600	.810

MATERIAL: SEE NOTE 1	TOLERANCES ON DIMENSIONS UNLESS OTHERWISE SPECIFIED X" = ±2" .XX = ±.015 X/X = ±1/32 .XXX = ±.010 MACHINE FINISH = .125			<b>DFCI SOLUTIONS INC.</b> 425 UNION BOULEVARD. WEST ISLIP, NEW YORK 11795					
HEAT TREAT: SEE NOTE 2	PART NO. 122J-R4**T***-Z3CT	DRN. <i>Frank Basile</i> DATE 03-27-13		TITLE ST-1200 STUD AND GROMMET ASSEMBLY 122J-R4**T***-Z3CT					
FINISH: SEE NOTE 3		CHK. <i>Frank Basile</i> DATE 03-27-13							
THE FASTENER PARTS SHOWN IN THIS PRINT ARE PROPRIETARY ARTICLES TO WHICH DFCI SOLUTIONS INC., RETAINS THE EXCLUSIVE RIGHTS OF MANUFACTURE, USE AND SALE. THE PRINT OR DRAWING IS SUBMITTED IN CONFIDENCE AND DOES NOT CONVEY A LICENSE OR PERMISSION TO MANUFACTURE THE FASTENER OR FASTENER PARTS. (C) COPYRIGHT 2009, DFCI SOLUTIONS INC. ALL RIGHTS RESERVED.		ENG. <i>Robert Altkorn</i> DATE 03-27-13	SIZE <b>A</b>				FSCM NO. 72794	DWG. NO. C122J-R4-T	REV. <b>A</b>
	NEXT ASSY	USED ON	MFG. <i>Rashm Lubman</i> DATE 03-27-13				SCALE: NTS		WEIGHT:
		G.C. <i>Robert Altkorn</i> DATE 03-27-13	SALES.						