

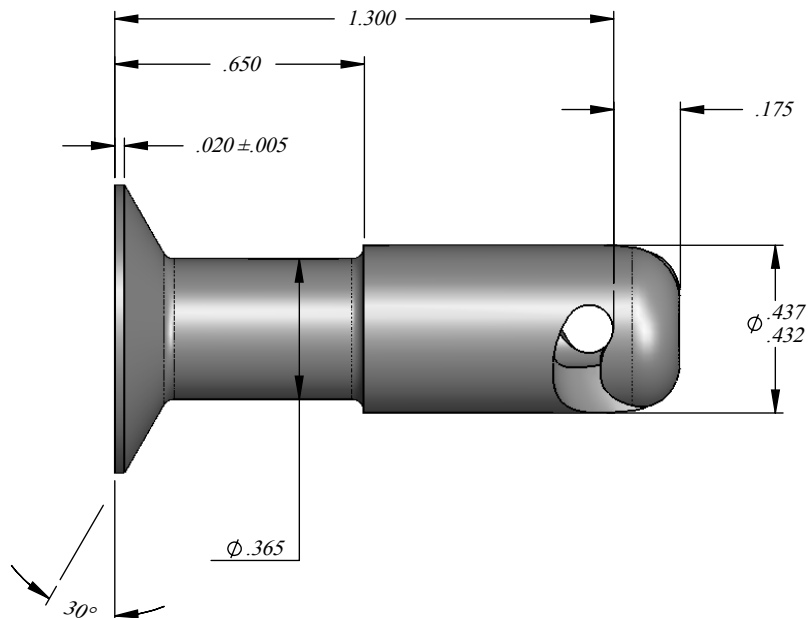

UNCONTROLLED

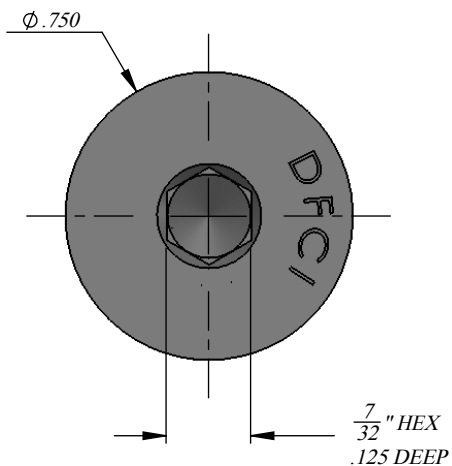
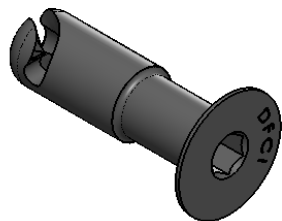

REVISIONS			
SYS	DESCRIPTION	DATE	APPROV
A	INITIAL RELEASE	05/11/10	F.B

MATERIAL: A.I.S.I C1022 OR 10B21	TOLERANCES ON DIMENSIONS UNLESS OTHERWISE SPECIFIED X* = ±2* .XX = ±.015 X/X = ±1/32 .XXX = ±.010 MACHINE FINISH = .125
HEAT TREAT: ROCKWELL C27-33	PART NO. 126J-7130-241780-Z3CT
FINISH: ZINC CLEAR TRIVALENT CHROMATE WITH SEALER PER ASTM-B-633, TYPE III, SC 2.	DRN W. Zhindon DATE 05/11/10
THE FASTENER PARTS SHOWN IN THIS PRINT ARE PROPERTY ARTICLES TO WHICH DFCI SOLUTIONS INC., RETAINS THE EXCLUSIVE RIGHTS OF MANUFACTURE, USE AND SALE. THE PRINT OR DRAWING IS SUBMITTED IN CONFIDENCE AND DOES NOT CONVEY A LICENSE OR PERMISSION TO MANUFACTURE THE FASTENER OR FASTENER PARTS. (C) COPYRIGHT 2009, DFCI SOLUTIONS INC. ALL RIGHTS RESERVED.	CHK. Frank Basile DATE 05/12/10
	ENG. Bill Velazquez DATE 05/12/10
	MFG. Bill Velazquez DATE 05/12/10
	G.C. Frank Basile DATE 05/12/10
NEXT ASSY	USED ON
APPLICATION BLOCK	SALES.

		DFCI SOLUTIONS INC. 425 UNION BOULEVARD. WEST ISLIP, NEW YORK 11795	
TITLE		ST-1200 LINE STUD 126J-7130-241780-Z3CT	
SIZE A	FSCM NO. 72794	DWG. NO. C126J-241780	REV. A
SCALE: NTS		WEIGHT:	SHEET 1 OF 1