

UNCONTROLLED

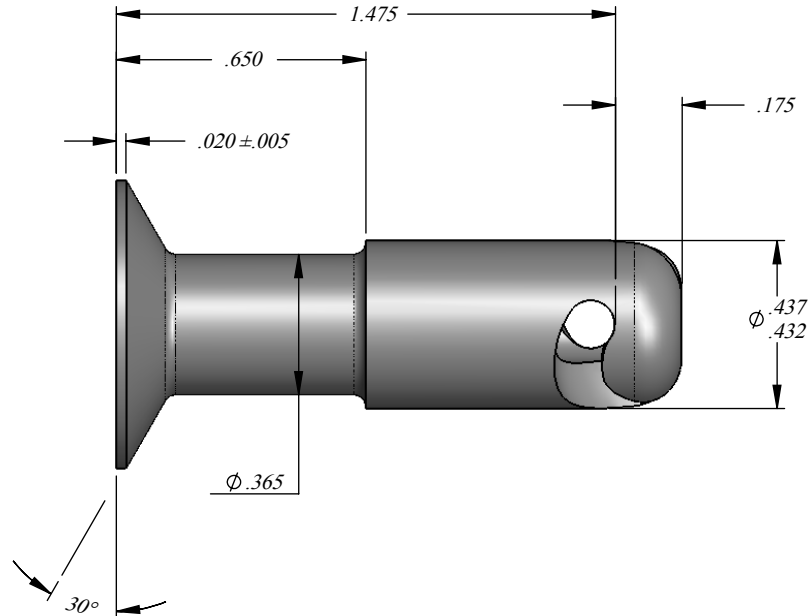
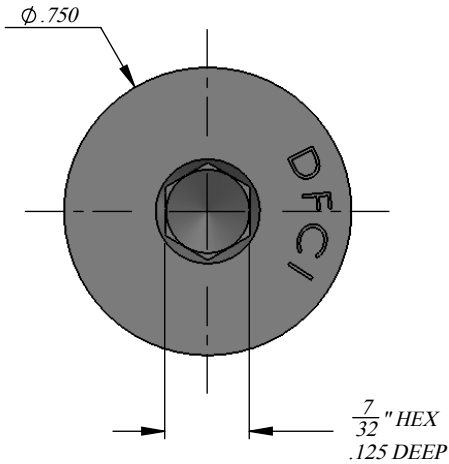
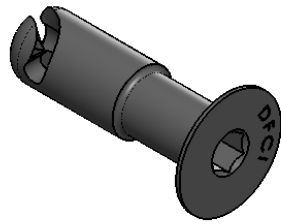

REVISIONS			
SYS	DESCRIPTION	DATE	APPROV
A	INITIAL RELEASE	05/11/10	F.B

PART NO.	FINISH	HEAT TREAT
126J-7148-241866-Z3CT	ZINC CLEAR TRIVALENT CHROMATE WITH SEALER PER ASTM-B-633, TYPE III, SC 2	ROCKWELL C27-33
126J-7148-241866-BNI	BLACK NITRIDE, COLOR: BLACK SEMI GLOSS	MINIMUM SURFACE HARDNESS: ROCKWELL C-50

MATERIAL:	A.I.S.I C1022 OR 10B21
HEAT TREAT:	NOTED
FINISH:	NOTED
<small>THE FASTENER PARTS SHOWN IN THIS PRINT ARE PROPERTY ARTICLES TO WHICH DFCI SOLUTIONS INC., RETAINS THE EXCLUSIVE RIGHTS OF MANUFACTURE, USE AND SALE. THE PRINT OF DRAWING IS SUBMITTED IN CONFIDENCE AND DOES NOT CONVEY A LICENSE OR PERMISSION TO MANUFACTURE THE FASTENER OR FASTENER PARTS.</small>	
(C) COPYRIGHT 2009, DFCI SOLUTIONS INC. ALL RIGHTS RESERVED.	

TOLERANCES ON DIMENSIONS UNLESS OTHERWISE SPECIFIED			
X* = ±2°		.XX = ±.015	
X/X = ±1/32		.XXX = ±.010	
MACHINE FINISH = .125			
PART NO.	DRN	DATE	
126J-7148-241866-xxx	W. Zhindon	05/11/10	
	CHK. Frank Basile	05/12/10	
	ENG. [Signature]	05/12/10	
	MFG. [Signature]	05/12/10	
	Q.C. [Signature]	05/12/10	
NEXT ASSY	USED ON	SALES.	DATE

DFCI SOLUTIONS INC.
425 UNION BOULEVARD.
WEST ISLIP, NEW YORK 11795

TITLE		ST-1200 LINE STUD	
		126J-7148-241866-xxx	
SIZE	FSCM NO.	DWG. NO.	REV.
A	72794	C126J-241866	A
SCALE: NTS		WEIGHT:	SHEET 1 OF 1