

REVISIONS			
SYS	DESCRIPTION	DATE	APPROV
A	PER ECN 1168 & 845	10-11-11	

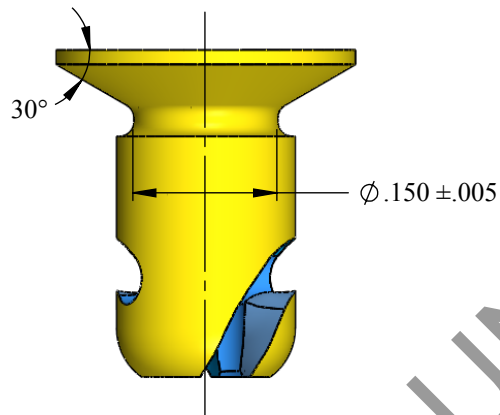

PART NUMBER	"G"	"U"
126J-325-24924-SS	.250	.100
126J-330-24924-SS	.300	.150
126J-335-24924-SS	.350	.175
126J-340-24924-SS	.400	.200
126J-345-24924-SS	.450	.225
126J-350-24924-SS	.500	.250
126J-355-24924-SS	.550	.275

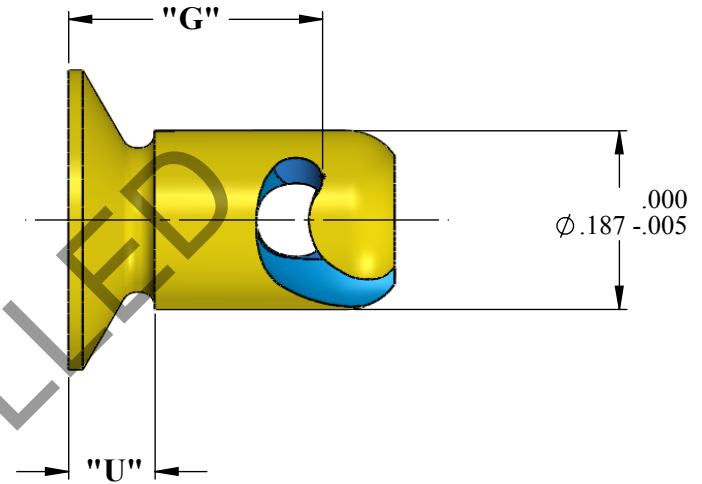
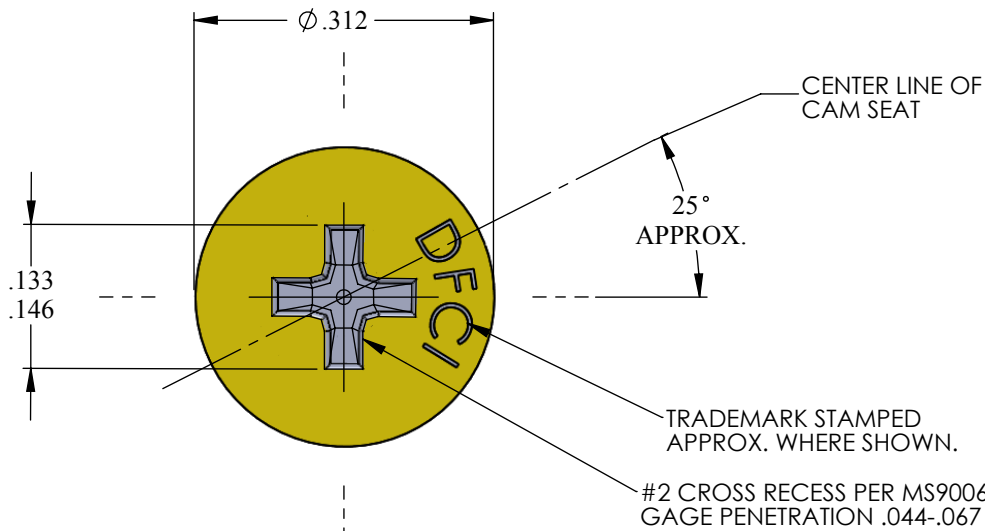
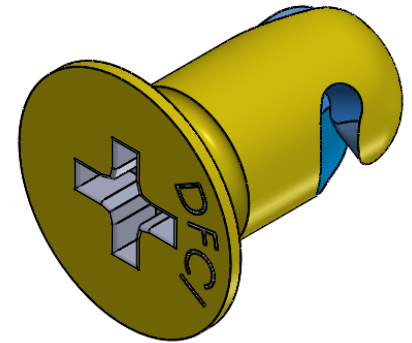

MATERIAL:	TYPE 303 STAINLESS STEEL
HEAT TREAT:	N/A
FINISH:	N/A
<small>THE FASTENER PARTS SHOWN IN THIS PRINT ARE PROPRIETARY ARTICLES TO WHICH DFCI SOLUTIONS INC., RETAINS THE EXCLUSIVE RIGHTS OF MANUFACTURE, USE AND SALE. THE PRINT OR DRAWING IS SUBMITTED IN CONFIDENCE AND DOES NOT CONVEY A LICENSE OR PERMISSION TO MANUFACTURE THE FASTENER OR FASTENER PARTS.</small> (C) COPYRIGHT 2009, DFCI SOLUTIONS INC. ALL RIGHTS RESERVED.	

TOLERANCES ON DIMENSIONS UNLESS OTHERWISE SPECIFIED			
X* = ±2°	.XX = ±.015	MACHINE FINISH = 125T	
X/X = ±1/32	.XXX = ±.010		
PART NO.	126J-3**-24924-SS	DRN	DATE
		Frank Basile	10-11-11
		CHK. Frank Basile	10-11-11
		ENG. Peter Altkorn	10-11-11
		MFG. Charles J. Parnell	10-11-11
		G.C. Peter Altkorn	10-11-11
NEXT ASSY	USED ON	SALES.	DATE
APPLICATION BLOCK			

		DFCI SOLUTIONS INC. 425 UNION BOULEVARD. WEST ISLIP, NEW YORK 11795	
TITLE			
126J-3**-24924-SS FLUSH HEAD PHILLIPS RECESS STUD			
SIZE	FSCM NO.	DWG. NO.	REV.
A	72794	C126J-3-24924	A
SCALE: NTS		WEIGHT:	SHEET 1 OF 1