

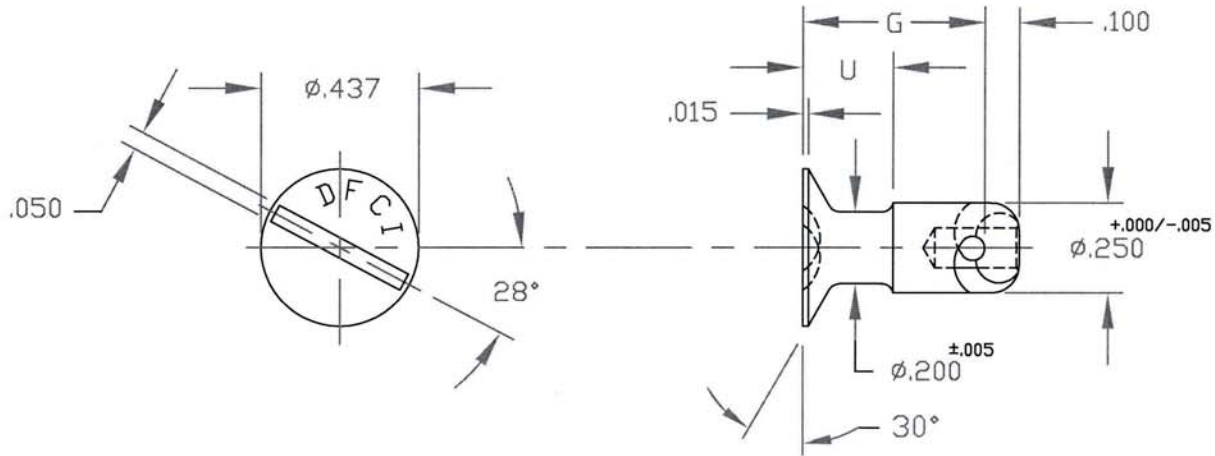

C126J-4 sht. 1of2 REV. *B*

UNCONTROLLED

REVISIONS			
SYM	DESCRIPTION	DATE	APPROV
B	CHNG FINISH ADD SHT2 ECN 1126	1-15-09	<i>FB</i>



FOR PART NO. REFER TO SHEET 2 of 2.

MAT'L PER NOTE 1.	TOLERANCES ON DIMENSIONS UNLESS OTHERWISE SPECIFIED X° = ±2° .XX = ±.015 X/X = ±1/32 .XXX = ±.010 MACHINE FINISH 125/		 DFCI SOLUTIONS INC. 425 UNION BOULEVARD WEST ISLIP, NEW YORK 11795	
HEAT TREAT PER NOTE 3.	PART NO.	DRN <i>S. Francis</i> DATE 1-11-05	TITLE 1200 LINE FLAT HD. STUD, 126J-4xx-Z3CT	
FINISH ZINC PLATE PER NOTE 2.		CHK <i>J. Basil</i> DATE 1-16-09		
THE FASTENER PARTS SHOWN IN THIS PRINT ARE PROPRIETARY ARTICLES TO WHICH DFCI SOLUTIONS INC. RETAINS THE EXCLUSIVE RIGHTS OF MANUFACTURE, USE AND SALE. THE PRINT OR DRAWING IS SUBMITTED IN CONFIDENCE AND DOES NOT CONVEY A LICENSE OR PERMISSION TO MANUFACTURE THE FASTENER OR FASTENER PARTS. © COPYRIGHT 2003, DFCI SOLUTIONS INC. ALL RIGHTS RESERVED. DATE: 07/01/06 FORM: DRAWING	NEXT ASSY	USED ON	SIZE A FSCM NO 72794 DWG. NO. C126J-4 REV. B	
	APPLICATION BLOCK	SALES	SCALE NTS WT.	SHEET 1 OF 2

The parts shown in this print are proprietary articles to which DFCI Solutions, Inc. retains the exclusive rights of manufacture, use and sale. The print or drawing is submitted in confidence and does not convey a license or permission to manufacture the parts. Copyright © 2009 by DFCI Solutions, Inc. All rights reserved.

UNCONTROLLED

REVISIONS			
SYM	DESCRIPTION	DATE	APPROV
B	CHNG FINISH ADD SHT2 ECN 1126	1-15-09	<i>FB</i>

PART NO. (STEEL STUD)	G	U
126J-430-Z3CT	.300	.175
126J-435-Z3CT	.350	
126J-440-Z3CT	.400	.200
126J-445-Z3CT	.450	.225
126J-450-Z3CT	.500	.250
126J-455-Z3CT	.550	.275
126J-460-Z3CT	.600	.300
126J-465-Z3CT	.650	
126J-470-Z3CT	.700	.350
126J-475-Z3CT	.750	
126J-480-Z3CT	.800	.400
126J-485-Z3CT	.850	
126J-490-Z3CT	.900	.500
126J-495-Z3CT	.950	
126J-4100-Z3CT	1.000	
126J-4110-Z3CT	1.100	
126J-4120-Z3CT	1.200	.600
126J-4130-Z3CT	1.300	
126J-4140-Z3CT	1.400	
126J-4150-Z3CT	1.500	
126J-4160B850-Z3CT	1.600	.850

NOTES:

- MATERIAL: PER A.I.S.I 8620 STEEL OR TYPE 303 ST. STEEL.
- FINISH:
ZINC PLATE PER ASTM-B-633, TYPE III, SC 2, CLEAR TRIVALENT CHROMATE WITH SEALER. (RoHS COMPLIANT) FINISH SUFFIX: -Z3CT
THE ABOVE MENTIONED FINISH WILL BE SUPPLIED AS THE STANDARD FINISH, UPON DEPLETION OF EXISTING STOCK WHICH ARE FINISHED AS FOLLOWS: ZINC PLATE PER ASTM-B-633, TYPE III, SC 2, CLEAR CHROMATE. FINISH SUFFIX -Z3C.
- HEAT TREATMENT:
STEEL STUD ONLY: ROCKWELL C27 - 33.
- FOR PART NO. OF STUD MADE FROM ST. STEEL, REMOVE SUFFIX -Z3CT FROM P/N AND ADD "-SS" EXAMPLE 126J-430-SS.
- FOR THE APPLICATION OF ALTERNATIVE FINISHES, REMOVE SUFFIX -Z3CT FROM THE PART NO. AND ADD THE REQUIRED FINISH TO THE PART NO. SUFFIX. *EXAMPLE FOR BLACK ZINC TRIVALENT CHROMATE FINISH, THE PART NO. IS 126J-430-Z3BT.
- PLEASE VISIT WWW.DFCIS.COM/C126J-4 FOR A LIST OF AVAILABLE FINISHES.

MAT'L PER NOTE 1.	TOLERANCES ON DIMENSIONS UNLESS OTHERWISE SPECIFIED X = ±2' .XX = ±.015 X/X = ±1/32 .XXX = ±.010 MACHINE FINISH 125T		 DFCI SOLUTIONS INC. 425 UNION BOULEVARD WEST ISLIP, NEW YORK 11795	
HEAT TREAT PER NOTE 3.	PART NO.	DRN <i>S. Francis</i> DATE 1-11-05	TITLE 1200 LINE FLAT HD. STUD, 126J-4xx-Z3CT	
FINISH ZINC PLATE PER NOTE 2.		CHK <i>F. Basile</i> DATE 1-16-09	SIZE A	FSCM NO 72794
<small>THE FASTENER PARTS SHOWN IN THIS PRINT ARE PROPRIETARY ARTICLES TO WHICH DFCI SOLUTIONS INC. RETAINS THE EXCLUSIVE RIGHTS OF MANUFACTURE, USE AND SALE. THE PRINT OR DRAWING IS SUBMITTED IN CONFIDENCE AND DOES NOT CONVEY A LICENSE OR PERMISSION TO MANUFACTURE THE FASTENER OR FASTENER PARTS.</small> © COPYRIGHT 2003, DFCI SOLUTIONS INC. ALL RIGHTS RESERVED. DATE: 07/01/06 FORM: DRAWING	NEXT ASSY	USED ON	DWG. NO. C126J-4	REV. B
	APPLICATION BLOCK	SALES	SCALE NTS	WT.
				SHEET 2 OF 2