

PART NUMBER	L	G	U	WEIGHT	
				LBS.	GRAMS
1631-4208-Z3CT	.41 [10.5]	.315 [8]	.12 [3]	.0043	1.950
1631-4209-Z3CT	.45 [11.5]	.354 [9]	.16 [4]	.0046	2.086
1631-4210-Z3CT	.49 [12.5]	.394 [10]	.20 [5]	.0048	2.177
1631-4211-Z3CT	.53 [13.5]	.433 [11]	.24 [6]	.0050	2.268
1631-4212-Z3CT	.57 [14.5]	.472 [12]	.28 [7]	.0053	2.404
1631-4213-Z3CT	.61 [15.5]	.512 [13]	.32 [8]	.0055	2.495
1631-4214-Z3CT	.65 [16.5]	.551 [14]	.35 [9]	.0057	2.585
1631-4215-Z3CT	.69 [17.5]	.590 [15]	.39 [10]	.0060	2.721
1631-4216-Z3CT	.73 [18.5]	.630 [16]	.43 [11]	.0062	2.812
1631-4217-Z3CT	.77 [19.5]	.669 [17]	.47 [12]	.0065	2.948
1631-4218-Z3CT	.81 [20.5]	.709 [18]	.51 [13]	.0067	3.039
1631-4219-Z3CT	.85 [21.5]	.748 [19]	.55 [14]	.0069	3.130
1631-4220-Z3CT	.89 [22.5]	.787 [20]	.59 [15]	.0071	3.220
1631-4221-Z3CT	.93 [23.5]	.827 [21]	.63 [16]	.0074	3.357
1631-4222-Z3CT	.97 [24.5]	.866 [22]	.67 [17]	.0076	3.447
1631-4223-Z3CT	1.01 [25.5]	.905 [23]	.71 [18]	.0079	3.551
1631-4224-Z3CT	1.05 [26.5]	.945 [24]	.75 [19]	.0081	3.656

REVISIONS			
SYS	DESCRIPTION	DATE	APPROV
E	PER ECN 1168	09/18/13	

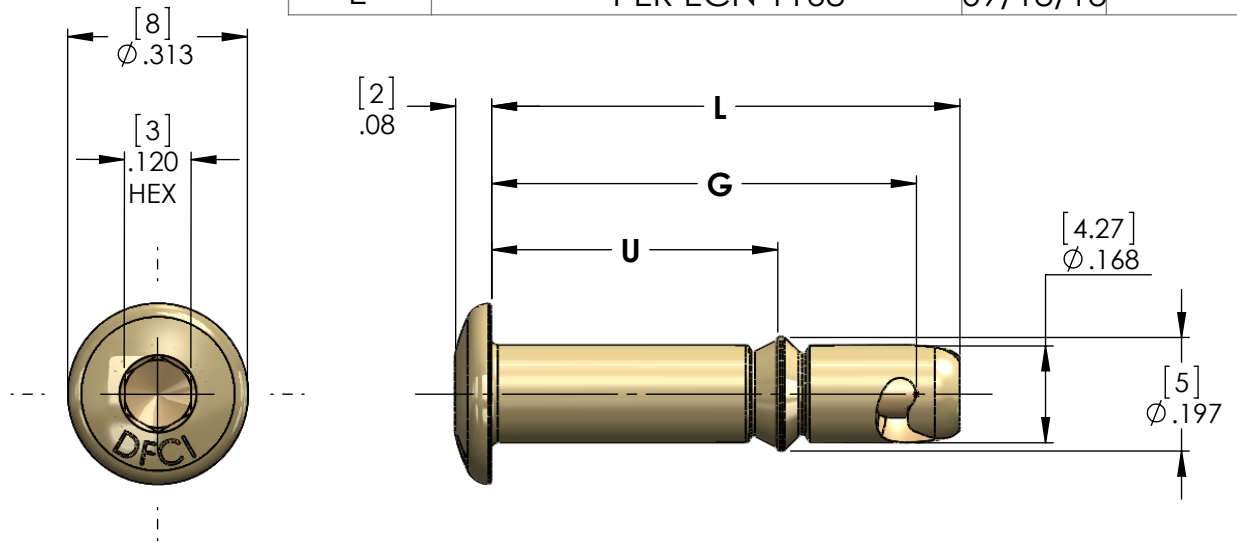

NOTES:

1. FINISH: ZINC PLATE PER ASTM-B-633, TYPE III, SC2, CLEAR TRIVALENT CHROMATE WITH SEALER.
2. PLEASE VISIT www.dfcis.com/c1631-42 FOR A LIST OF AVAILABLE FINISHES.
3. ALL PRIMARY DIMENSIONS ARE IN INCHES AND DIMENSIONS SHOWN BETWEEN [***] ARE IN MILLIMETERS.

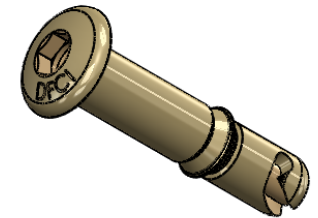

UNCONTROLLED

MATERIAL: A.I.S.I 8620 OR 10B21 STEEL		TOLERANCES ON DIMENSIONS UNLESS OTHERWISE SPECIFIED X* = ±2% X/X = ±1/32 .XX = ±.015 .XXX = ±.010 MACHINE FINISH = .125			 DFCI SOLUTIONS INC. 425 UNION BOULEVARD. WEST ISLIP, NEW YORK 11795	
HEAT TREAT: CASE HARDENED		PART NO. SEE TABLE	DRN: Frank Basile	DATE: 09/18/13		
FINISH: SEE NOTE 1			CHK: Frank Basile	DATE: 09/18/13	TITLE: PX-1600 SOCKET HEAD STUD 1631-42**-Z3CT	
THE FASTENER PARTS SHOWN IN THIS PRINT ARE PROPRIETARY ARTICLES TO WHICH DFCI SOLUTIONS INC., RETAINS THE EXCLUSIVE RIGHTS OF MANUFACTURE, USE AND SALE. THE PRINT OR DRAWING IS SUBMITTED IN CONFIDENCE AND DOES NOT CONVEY A LICENSE OR PERMISSION TO MANUFACTURE THE FASTENER OR FASTENER PARTS. (C) COPYRIGHT 2009, DFCI SOLUTIONS INC. ALL RIGHTS RESERVED.			ENG: [Signature]	DATE: 09/18/13		
			MFG: Rashid Ibrahim	DATE: 09/18/13		
			G.C: [Signature]	DATE: 09/18/13	SIZE: A	
			SALES:		FSCM NO: 72794	
					DWG. NO. C1631-42	
					REV. E	
					SCALE: NTS	
					WEIGHT:	
					SHEET 1 OF 1	