

UNCONTROLLED

C1632-6101 REV. B

REVISIONS			
SYM	DESCRIPTION	DATE	APPROV
B	CHNG DWG SHT. ECN 1027	3-1-07	R. OLSON

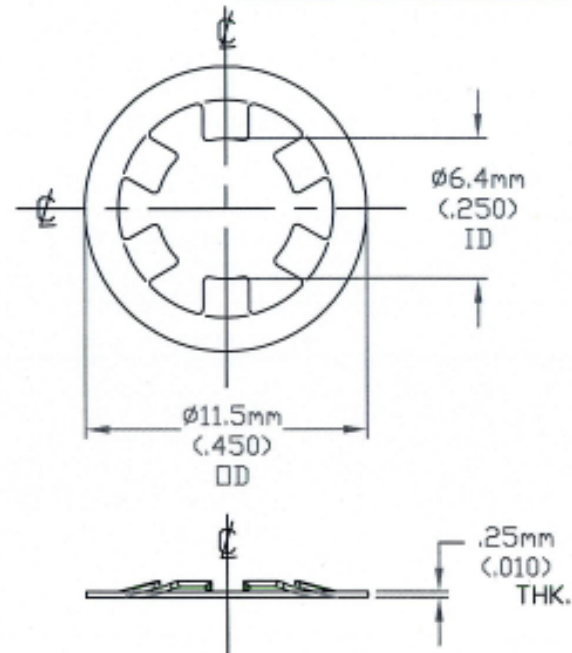

SIZE 6 RETAINER  
(SEE NOTE 1)

RING P/N	FINISH
1632-6101-Z3CT	ZINC PLATE PER ASTM-B-633, TYPE III, SC 2, CLEAR TRIVALENT CHROMATE.

NOTE:

- FOR SIZE 4 RETAINER P/N 1632-4101-Z3CT SEE DRAWING NO. C1632-4101.

ALL TOLERANCES ARE IN INCHES

MATL HIGH CARBON STEEL.		TOLERANCES ON DIMENSIONS UNLESS OTHERWISE SPECIFIED X' = ±2" .XX = ± .015 X/X = ±1/32 .XXX = ± .010 MACHINE FINISH 125T			<b>DFCI SOLUTIONS INC.</b> 425 UNION BOULEVARD WEST ISLIP, NEW YORK 11795	
HEAT TREAT SPRING TEMPER.		PART NO.	DRN S. FRANZOS	DATE 11-21-06	TYPE PX-1600 SIZE 6 RETAINER. 1632-6101-Z3CT	
FINISH AS NOTED.			CHK F. BASIL	DATE 3-2-07		
			ENG R. OLSON	DATE 3/2/07		
			MFG JS	DATE 3-7-07	SIZE A	FSCM NO 72794
		NEXT ASSY	USED ON	DATE 3/2/07	DWG. NO. C1632-6101	REV. B
<small>THE FASTENER PARTS SHOWN ON THIS PRINT ARE PROPRIETARY ARTICLES TO WHICH DFCI SOLUTIONS INC. RETAINS THE EXCLUSIVE RIGHTS OF MANUFACTURE, USE AND SALE. THE PRINT OR DRAWING IS SUBMITTED IN CONFIDENCE AND DOES NOT CONVEY A LICENSE OR PERMISSION TO MANUFACTURE THE FASTENER OR FASTENER PARTS.</small> <small>DATE: 07/01/06 FORM: DRAWING</small>		APPLICATION BLOCK	SALES	DATE	SCALE NTS	WT. SHEET 1 OF 1