

UNCONTROLLED

C2350F SHT. 1of2 REV. D

REVISIONS			
SYM	DESCRIPTION	DATE	APPROV
D	ADD TOL.& WEIGHT ECN 1124	1-5-09	<i>FB</i>

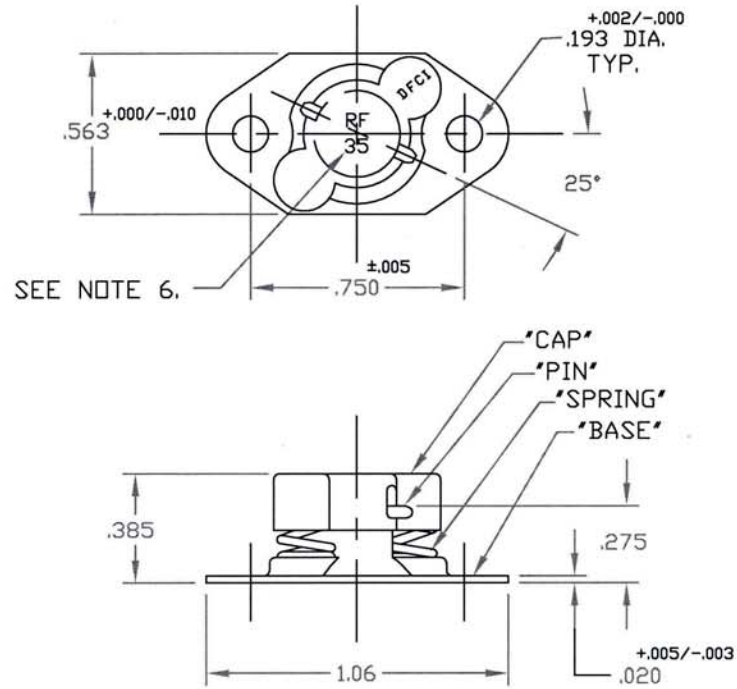

FOR PART NO. REFER TO SHEET 2of2.

MAT'L PER NOTE 2.	TOLERANCES ON DIMENSIONS UNLESS OTHERWISE SPECIFIED X° = ±2° .XX = ±.015 X/X = ±1/32 .XXX = ±.010		MACHINE FINISH 125/		DFCI SOLUTIONS INC. 425 UNION BOULEVARD WEST ISLIP, NEW YORK 11795	
HEAT TREAT PER NOTE 2.	PART NO.	DRN <i>S. Ferraro</i>	DATE 5-5-04	SU-2300 RECEPTACLE ASSY. 2350-18F-Z3CT		
FINISH PER NOTE 1.		CHK <i>J. Basile</i>	DATE 1-6-09	SIZE A	FSCM NO 72794	DWG. NO. C2350F
<small>THE FASTENER PARTS SHOWN IN THIS PRINT ARE PROPRIETARY ARTICLES TO WHICH DFCI SOLUTIONS INC. RETAINS THE EXCLUSIVE RIGHTS OF MANUFACTURE, USE AND SALE. THE PRINT OR DRAWING IS SUBMITTED IN CONFIDENCE AND DOES NOT CONVEY A LICENSE OR PERMISSION TO MANUFACTURE THE FASTENER OR FASTENER PARTS.</small>	NEXT ASSY	USED ON	DATE 1-6-09	SCALE NTS	WT.	REV. D
<small>© COPYRIGHT 2009, DFCI SOLUTIONS INC. ALL RIGHTS RESERVED.</small> DATE: 07/01/06 FORM: DRAWING	APPLICATION BLOCK	SALES	DATE 1-6-09	SHEET 1 OF 2		

The parts shown in this print are proprietary articles to which DFCI Solutions, Inc. retains the exclusive rights of manufacture, use and sale. The print or drawing is submitted in confidence and does not convey a license or permission to manufacture the parts. Copyright © 2009 by DFCI Solutions, Inc. All rights reserved.

UNCONTROLLED

REVISIONS			
SYM	DESCRIPTION	DATE	APPROV
D	ADD TOL.& WEIGHT ECN 1124	1-5-09	FAB

NOTES:

1. FINISH:
ZINC PLATE PER ASTM-B-633, TYPE III, SC 2, CLEAR TRIVALENT CHROMATE WITH SEALER. (RoHS COMPLIANT) FINISH SUFFIX: -Z3CT
THE ABOVE MENTIONED FINISH WILL BE SUPPLIED AS THE STANDARD FINISH, UPON DEPLETION OF EXISTING STOCK WHICH ARE FINISHED AS FOLLOWS: CADMIUM PLATE PER QQ-P-416, TYPE I, CLASS 2, CLEAR CHROMATE. FINISH SUFFIX -C3C.
2. MATERIAL:
BASE S.A.E 4130 STEEL, HEAT TREAT TO ROCKWELL C37-40.
PIN & *SPRING* STEEL MUSIC WIRE.
CAP PER S.A.E 1008/1010 STEEL.
3. TWO (2) SPACERS P/N 2350-18F-5-Z3CT ARE SUPPLIED W/EACH 2350-18F-Z3CT RECEPTACLE.
4. TWO (2) SPACERS P/N 2350-18F-5L-Z3CT ARE SUPPLIED W/EACH 2350-18F-LS-Z3CT RECEPTACLE. THIS RECEPTACLE USES SLIGHTLY LONGER SPACERS WHICH IS TO BE USED WHEN ATTACHING TO A PANEL MADE FROM SOFT MATERIAL.
5. FOR THE APPLICATION OF ALTERNATIVE FINISHES, REMOVE SUFFIX -Z3CT FROM THE PART NO. AND ADD THE REQUIRED FINISH TO THE PART NO. SUFFIX.
*EXAMPLE FOR BLACK ZINC TRIVALENT CHROMATE FINISH, THE PART NO. IS 2350-18F-Z3BT
6. PART WILL BE MARKED AS SHOWN (RF 35) UNTILL DEPLETION OF EXISTING STOCK. THEREAFTER PART WILL BE MARKED WITH FOLLOWING DESIGNATION *F35*.
7. PLEASE VISIT WWW.DFCIS.COM/C2350F FOR A LIST OF AVAILABLE FINISHES.

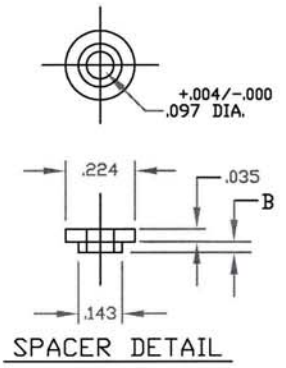

SPACER	B DIM.	MATERIAL
2350-18F-5-Z3CT	.032	A.I.S.I 1117, 1214
2350-18F-5L-Z3CT	.037	DR 8620 STEEL.

RECEPTACLE ASSY, P/N	SPACER	WEIGHT (LBS.)
2350-18F-Z3CT	SUPPLIED PER NOTE 3	.0065
2350-18F-LS-Z3CT	SUPPLIED PER NOTE 4	

MAT'L PER NOTE 2.		TOLERANCES ON DIMENSIONS UNLESS OTHERWISE SPECIFIED X* = ±2* .XX = ± .015 X/X = ±1/32 .XXX = ± .010 MACHINE FINISH 125/T			DFCI SOLUTIONS INC. 425 UNION BOULEVARD WEST ISLIP, NEW YORK 11795	
HEAT TREAT PER NOTE 2.		PART NO.	DRN S. FRANCIS	DATE 5-5-04	SU-2300 RECEPTACLE ASSY. 2350-18F-Z3CT	
FINISH PER NOTE 1.			CHK F. BASILE	DATE 1-6-09	SIZE A FSCM NO 72794 DWG. NO. C2350F REV. D	
<small>THE FASTENER PARTS SHOWN IN THIS PRINT ARE PROPRIETARY ARTICLES TO WHICH DFCI SOLUTIONS INC. RETAINS THE EXCLUSIVE RIGHTS OF MANUFACTURE, USE AND SALE. THE PRINT OR DRAWING IS SUBMITTED IN CONFIDENCE AND DOES NOT CONVEY A LICENSE OR PERMISSION TO MANUFACTURE THE FASTENER OR FASTENER PARTS.</small>		NEXT ASSY	USED ON	DATE 1/6/09	SCALE NTS WT. SHEET 2 OF 2	
<small>© COPYRIGHT 2009, DFCI SOLUTIONS INC. ALL RIGHTS RESERVED</small>		APPLICATION BLOCK		SALES	<small>DATE 1/6/09</small>	