

UNCONTROLLED

C2350F SHT. 1 of 2 REV.

REVISIONS			
SYM	DESCRIPTION	DATE	APPROV
E	PER ECN 1192	08-18-2010	ZB

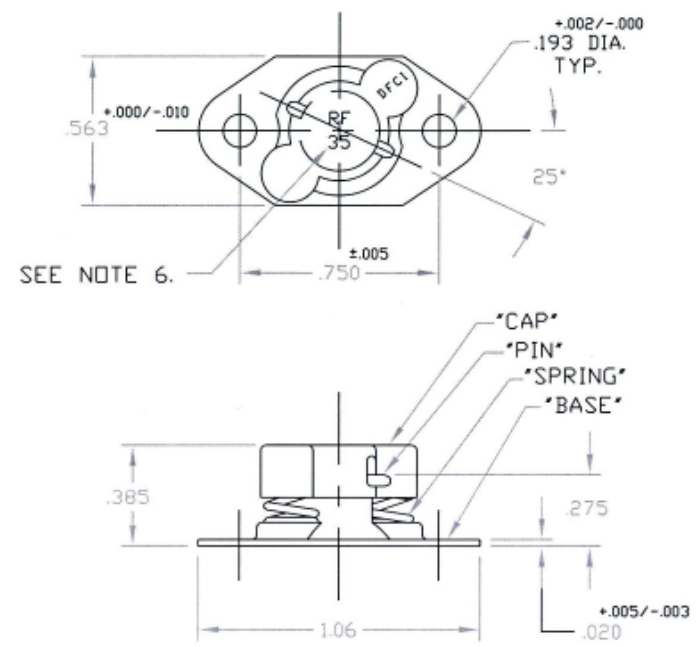

FOR PART NO. REFER TO SHEET 2 of 2.

MAT'L PER NOTE 2.	TOLERANCES ON DIMENSIONS UNLESS OTHERWISE SPECIFIED X = ±.2    .XX = ±.015 X/X = ±1/32    .XXX = ±.010    MACHINE FINISH .125		DFCI SOLUTIONS INC. 425 UNION BOULEVARD WEST ISLIP, NEW YORK 11795	
HEAT TREAT PER NOTE 2.	PART NO.	DRN S. F	DATE 5-5-04	SU-2300 RECEPTACLE ASSY. 2350-18F-Z3CT
FINISH PER NOTE 1.		CHK F. Basil	DATE 8-18-10	
THE FASTENER PARTS SHOWN IN THIS PRINT ARE PROPRIETARY ARTICLES TO WHICH DFCI SOLUTIONS INC. RETAINS THE EXCLUSIVE RIGHTS OF MANUFACTURE, USE AND SALE. THE PRINT OR DRAWING IS SUBMITTED IN CONFIDENCE AND DOES NOT CONVEY A LICENSE OR PERMISSION TO MANUFACTURE THE FASTENER OR FASTENER PARTS.		ENG D. Nilsson	DATE 8/18/10	SIZE A
	NEXT ASSY	USED ON	MFG D. Nilsson	FSCM NO 72794
DATE: 07/01/06    FORM: DRAWING	SALES	DATE 8/18/10	DATE 8-18-10	DWG. NO. C2350F
APPLICATION BLOCK			SCALE NTS	WT. SHEET 1 OF 2

The parts shown in this print are proprietary articles to which DFCI Solutions, Inc. retains the exclusive rights of manufacture, use and sale. The print or drawing is submitted in confidence and does not convey a license or permission to manufacture the parts. Copyright © 2009 by DFCI Solutions, Inc. All rights reserved.

UNCONTROLLED

REVISIONS			
SYM	DESCRIPTION	DATE	APPROV
E	PER ECN I192	08-18-2010	<i>ZB</i>

NOTES:

1. FINISH:

ZINC PLATE PER ASTM-B-633, TYPE III, SC 2, CLEAR TRIVALENT CHROMATE WITH SEALER. (ROHS COMPLIANT) FINISH SUFFIX: -Z3CT  
 THE ABOVE MENTIONED FINISH WILL BE SUPPLIED AS THE STANDARD FINISH, UPON DEPLETION OF EXISTING STOCK WHICH ARE FINISHED AS FOLLO: CADMIUM PLATE PER QQ-P-416, TYPE I, CLASS 2, CLEAR CHROMATE. FINISH SUFFIX -C3C.

2. MATERIAL:

\*BASE\* S.A.E 4130 STEEL, HEAT TREAT TO ROCKWELL C37-40.  
 \*PIN\* & \*SPRING\* STEEL MUSIC WIRE.  
 \*CAP\* PER S.A.E 1008/1010 STEEL.

3. TWO ( 2 ) SPACERS P/N 2350-18F-5-Z3CT ARE SUPPLIED W/EACH 2350-18F-Z3CT RECEPTACLE.

4. TWO ( 2 ) SPACERS P/N 2350-18F-5L-Z3CT ARE SUPPLIED W/EACH 2350-18F-LS-Z3CT RECEPTACLE. THIS RECEPTACLE USES SLIGHTLY LONGER SPACERS WHICH IS TO BE USED WHEN ATTACHING TO A PANEL MADE FROM SOFT MATERIAL.

5. FOR THE APPLICATION OF ALTERNATIVE FINISHES, REMOVE SUFFIX -Z3CT FROM THE PART NO. AND ADD THE REQUIRED FINISH TO THE PART NO. SUFFIX. \*EXAMPLE FOR BLACK ZINC TRIVALENT CHROMATE FINISH, THE PART NO. IS 2350-18F-Z3BT

6. PART WILL BE MARKED AS SHOWN ( RF 35 ) UNTILL DEPLETION OF EXISTING STOCK. THEREAFTER PART WILL BE MARKED WITH FOLLOWING DESIGNATION \*F35\*.

7. PLEASE VISIT WWW.DFCIS.COM/C2350F FOR A LIST OF AVAILABLE FINISHES.

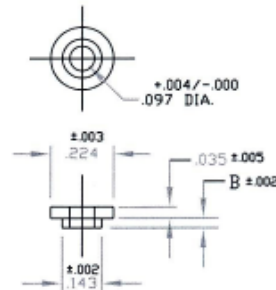

SPACER DETAIL

SPACER	B DIM.	MATERIAL
2350-18F-5-Z3CT	.032	A.I.S.I 1117, 1214
2350-18F-5L-Z3CT	.037	OR 8620 STEEL.

RECEPTACLE ASSY. P/N	SPACER	WEIGHT ( LBS. )
2350-18F-Z3CT	SUPPLIED PER NOTE 3	.0065
2350-18F-LS-Z3CT	SUPPLIED PER NOTE 4	

MAT'L PER NOTE 2.	TOLERANCES ON DIMENSIONS UNLESS OTHERWISE SPECIFIED X = ±2' .XX = ± .015 X/X = ±1/32 .XXX = ± .010		MACHINE FINISH .125		DFCI SOLUTIONS INC. 425 UNION BOULEVARD WEST ISLIP, NEW YORK 11795	
HEAT TREAT PER NOTE 2.	PART NO.	DRN S. F	DATE 5-5-04	TITLE SU-2300 RECEPTACLE ASSY. 2350-18F-Z3CT		
FINISH PER NOTE 1.		CHK <i>F. Basil</i>	DATE 8-18-10	SIZE A		
		ENG <i>B. Wilton</i>	DATE 8/18/10	FSCM NO 72794	DWG. NO. C2350F	REV. E
		MFG <i>B. Wilton</i>	DATE 8/18/10	SCALE NTS	WT.	SHEET 2 OF 2
	NEXT ASSY	USED ON	DATE	APPLICATION BLOCK		
		SALES	DATE			

DATE: 07/01/06 FORM: DRAWING