

UNCONTROLLED

C2351-241504 REV. A

REVISIONS			
SYM	DESCRIPTION	DATE	APPROV
A	INITIAL RELEASE PER ECN 845	5-30-07	<i>R. OLSON</i>

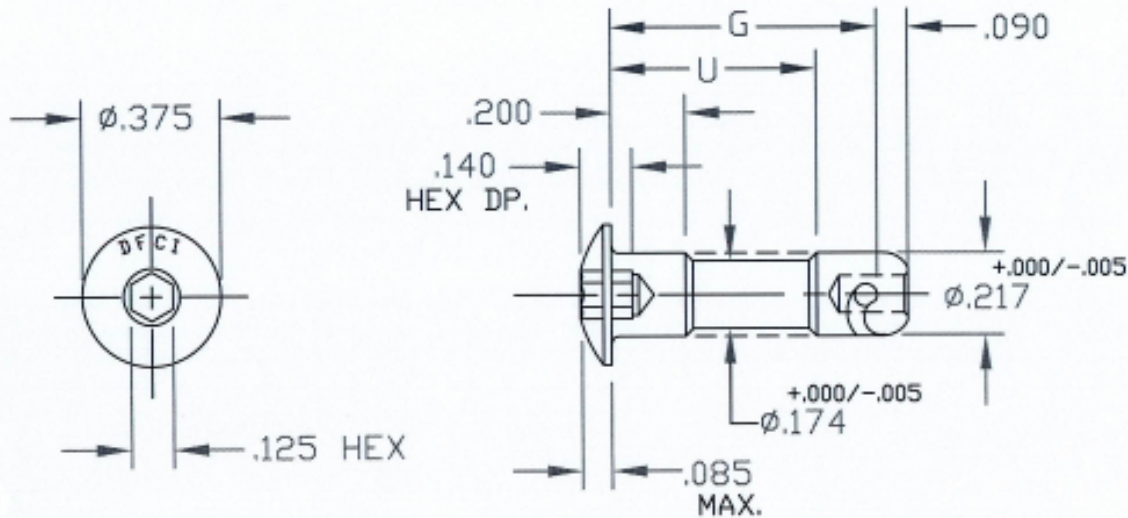

PART NO.	G	U
2351-SH20-90-241504	1.130	.900
2351-SH20-126-241504	1.490	1.260
2351-SH20-153-241504	1.760	1.530

MAT'L TYPE 303 ST. STEEL.	TOLERANCES ON DIMENSIONS UNLESS OTHERWISE SPECIFIED X* = ±2* .XX = ±.015 X/X = ±1/32 .XXX = ±.010		MACHINE FINISH 125T		DFCI SOLUTIONS INC. 425 UNION BOULEVARD WEST ISLIP, NEW YORK 11795	
HEAT TREAT NONE.	PART NO.	DRN S. F. <i>R. OLSON</i>	DATE 5-30-07	SU-2300 HEX RECESS STUD, 2351-SH20-xx-241504.		
FINISH PASSIVATE PER QQ-P-35.		CHK <i>F. Basil</i>	DATE 5-30-07	SIZE A	FSCM NO 72794	DWG. NO. C2351-241504
<small>THE FASTENER PARTS SHOWN ON THIS PRINT ARE PROPRIETARY ARTICLES TO WHICH DFCI SOLUTIONS INC. RETAINS THE EXCLUSIVE RIGHTS OF MANUFACTURE, USE AND SALE. THE PRINT OR DRAWING IS SUBMITTED IN CONFIDENCE AND DOES NOT CONVEY A LICENSE OR PERMISSION TO MANUFACTURE THE PARTS OR FASTENER PARTS.</small>	NEXT ASSY	USED ON	ENG <i>R. OLSON</i>	DATE 5/30/07	REV. A	
<small>DATE: 07/01/06 FORM: DRAWING</small>	SALES	DATE	QC <i>B. Hildner</i>	DATE 5/30/07	SCALE NTS	WT.
	APPLICATION BLOCK					SHEET 1 OF 1