

UNCONTROLLED

C2356 REV. C

REVISIONS			
SYM	DESCRIPTION	DATE	APPROV
C	CHNG FINISH PER ECN 1152.	7-6-09	

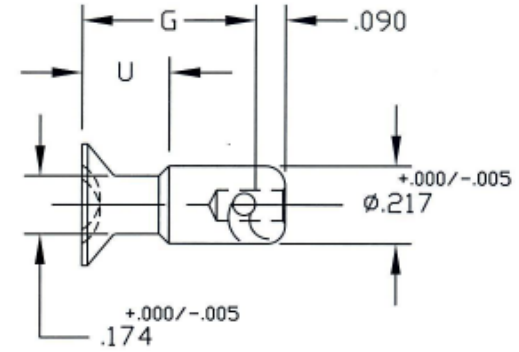
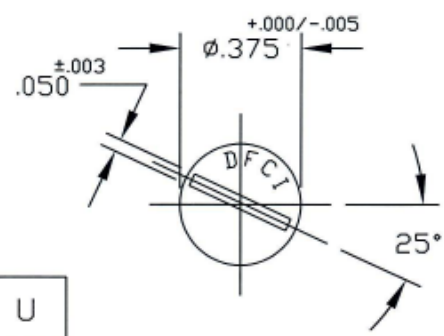

PART NO.	WEIGHT (LBS.)	G	U
2356-20-3-Z3CT	.0030	.260	.130
2356-20-5-Z3CT	.0032	.280	
2356-20-6-Z3CT	.0034	.290	.170
2356-20-9-Z3CT	.0036	.320	
2356-20-12-Z3CT	.0038	.350	.210
2356-20-15-Z3CT	.0040	.380	
2356-20-18-Z3CT	.0042	.410	.290
2356-20-21-Z3CT	.0044	.440	
2356-20-24-Z3CT	.0046	.470	.330
2356-20-27-Z3CT	.0048	.500	
2356-20-30-Z3CT	.0050	.530	.410
2356-20-33-Z3CT	.0052	.560	
2356-20-36-Z3CT	.0054	.590	.450
2356-20-39-Z3CT	.0056	.620	
2356-20-42-Z3CT	.0058	.650	.530
2356-20-45-Z3CT	.0060	.680	

NOTES:

- FINISH:  
ZINC PLATE PER ASTM-B-633, TYPE III, SC 2, CLEAR TRIVALENT CHROMATE WITH SEALER. (RoHS COMPLIANT) FINISH SUFFIX: -Z3CT  
THE ABOVE MENTIONED FINISH WILL BE SUPPLIED AS THE STANDARD FINISH, UPON DEPLETION OF EXISTING STOCK WHICH ARE FINISHED AS FOLLO: CADMIUM PLATE PER QQ-P-416, TYPE I, CLASS 2, CLEAR CHROMATE. FINISH SUFFIX -C3C.
- FOR THE APPLICATION OF ALTERNATIVE FINISHES, REMOVE SUFFIX -Z3CT FROM THE PART NO. AND ADD THE REQUIRED FINISH TO THE PART NO. SUFFIX. \*EXAMPLE FOR BLACK ZINC TRIVALENT CHROMATE THE P/N WILL BE 2356-20-3-Z3BT.
- PLEASE VISIT WWW.DFCIS.COM/C2356 FOR A LIST OF AVAILABLE FINISHES.

MAT'L PER A.I.S.I 8620 STEEL.		TOLERANCES ON DIMENSIONS UNLESS OTHERWISE SPECIFIED X/X = ±2* .XX = ±.015 X/X = ±1/32 .XXX = ±.010 MACHINE FINISH .125		DFCI SOLUTIONS INC. 425 UNION BOULEVARD WEST ISLIP, NEW YORK 11795	
HEAT TREAT ROCKWELL C30 - 38.		PART NO.	DRN S. FRAYAS DATE 2-10-04	TITLE SU-2300 LINE STUD, 2356-20-xx-Z3CT.	
FINISH PER NOTE 1.			CHK [Signature] DATE 7-10-09	SIZE A	
<small>THE FASTENER PARTS SHOWN IN THIS PRINT ARE PROPRIETARY ARTICLES TO WHICH DFCI SOLUTIONS INC. RETAINS THE EXCLUSIVE RIGHTS OF MANUFACTURE, USE AND SALE. THE PRINT OR DRAWING IS SUBMITTED IN CONFIDENCE AND DOES NOT CONVEY A LICENSE OR PERMISSION TO MANUFACTURE THE FASTENER OR FASTENER PARTS.</small> <small>© COPYRIGHT 2003, DFCI SOLUTIONS INC. ALL RIGHTS RESERVED.</small>			ENG B. Hildebrand DATE 7-10-09	FSCM NO 72794	DWG. NO. C2356
		NEXT ASSY	USED ON	QC B. Hildebrand DATE 7-10-09	REV. C
APPLICATION BLOCK		SALES	DATE	SCALE NTS	WT.
				SHEET	1 OF 1

DATE: 07/01/06 FORM: DRAWING