

UNCONTROLLED

C2500-241575 SHT. 1of2 REV. **A**

REVISIONS			
SYM	DESCRIPTION	DATE	APPROV
A	NITIAL RELEASE PER ECN 845.	10-9-07	<i>R. OLSON</i>

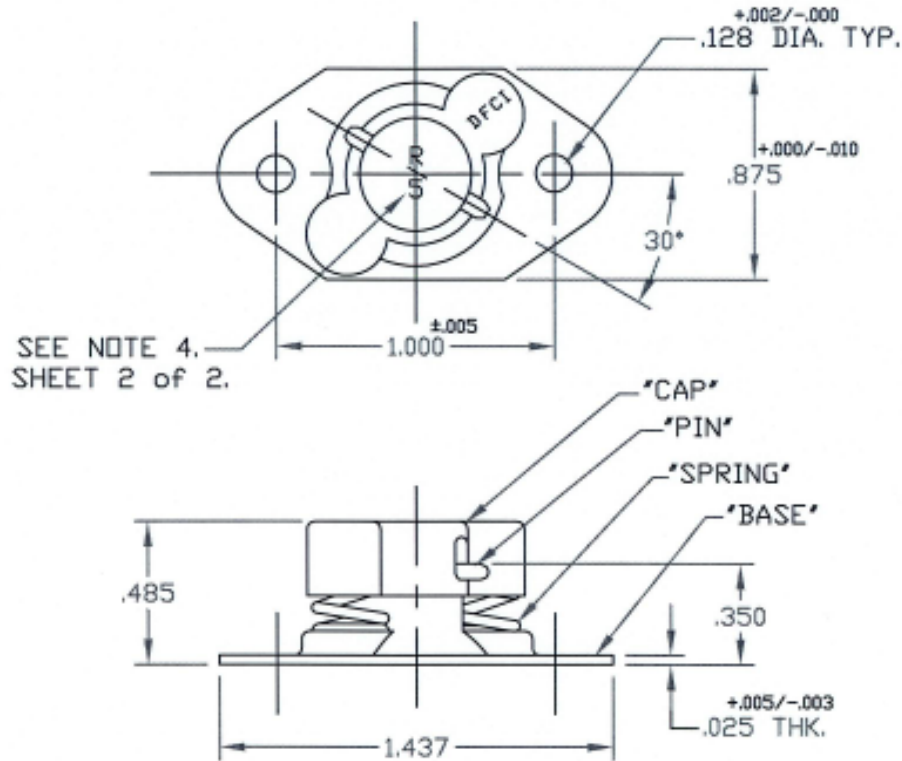

SEE NOTE 4.
SHEET 2 of 2.

FOR PART NO. REFER TO SHEET 2of2.

MAT'L PER NOTE 2.	TOLERANCES ON DIMENSIONS UNLESS OTHERWISE SPECIFIED $X^\circ = \pm 2^\circ$.XX $\pm .015$ X/X $\pm 1/32$.XXX $\pm .010$ MACHINE FINISH 125T		DFCI SOLUTIONS INC. 425 UNION BOULEVARD WEST ISLIP, NEW YORK 11795	
HEAT TREAT PER NOTE 2.	PART NO.	DRN <i>S. FRANKS</i>	DATE 10-9-07	SU-2300 RECEPTACLE ASSY. 2500-18-241575-N4F
FINISH PER NOTE 1.		CHK <i>F. Basil</i>	DATE 10-10-07	
		ENG <i>R. OLSON</i>	DATE 10/11/07	SIZE A FSCM NO 72794 DWG. NO. C2500-241575 REV. A
		MFG <i>R. Hill</i>	DATE 10-11-07	SCALE NTS WT. SHEET 1 OF 2
	NEXT ASSY	USED ON	DATE	
	APPLICATION BLOCK	SALES	DATE	

DATE: 07/01/06 FORM: DRAWING

UNCONTROLLED

REVISIONS			
SYM	DESCRIPTION	DATE	APPROV
A	INITIAL RELEASE PER ECN 845.	10-9-07	R. OLSEN

RECEPTACLE
ASSY. P/N
2500-18-241575-N4F

NOTES:

1. FINISH: BASE AND CAP:
NICKEL PLATE PER QQ-N-290, CLASS 1, GRADE F.
PIN AND SPRING ARE NATURAL.
2. MATERIAL:
"BASE" A.I.S.I 4130 STEEL, HEAT TREAT TO
ROCKWELL C37-40.
"CAP" PER A.I.S.I 1008/1010 STEEL.
"PIN" & "SPRING" 17-7 ST. STEEL.
3. PART WILL BE MARKED AS SHOWN < R 5 > UNTILL
DEPLETION OF EXISTING STOCK. THEREAFTER PART
WILL BE MARKED WITH FOLLOWING DESIGNATION "5".
4. PLEASE VISIT WWW.DFCIS.COM/C2500-241575 FOR A LIST
OF AVAILABLE FINISHES.

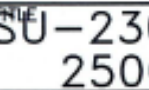
MAT'L PER NOTE 2.	TOLERANCES ON DIMENSIONS UNLESS OTHERWISE SPECIFIED X = ±2" .XX = ±.015 X/X = ±1/32 .XXX = ±.010		MACHINE FINISH 125T		 DFCI SOLUTIONS INC. 425 UNION BOULEVARD WEST ISLIP, NEW YORK 11795		
HEAT TREAT PER NOTE 2.	PART NO.	DRN S. FRANKS	DATE 10-9-07	 SU-2300 RECEPTACLE ASSY. 2500-18-241575-N4F			
FINISH PER NOTE 1.		CHK F. BARD	DATE 10-10-07	SIZE A	FSCM NO 72794	DWG. NO. C2500-241575	REV. A
<small>THE PARTS SHOWN IN THIS PRINT ARE PROPRIETARY ARTICLES TO WHICH DFCI SOLUTIONS INC. RETAINS THE EXCLUSIVE RIGHTS OF MANUFACTURE, USE AND SALE. THE PRINT OR DRAWING IS SUBMITTED IN CONFIDENCE AND DOES NOT CONVEY A LICENSE OR PERMISSION TO MANUFACTURE THE PARTS OR PARTS THEREOF.</small>	NEXT ASSY	USED ON	DATE 10-11-07	SCALE NTS	WT.	SHEET 2 OF 2	
<small>DATE: 07/01/06 FORM: DRAWING</small>	APPLICATION BLOCK	SALES	DATE				