

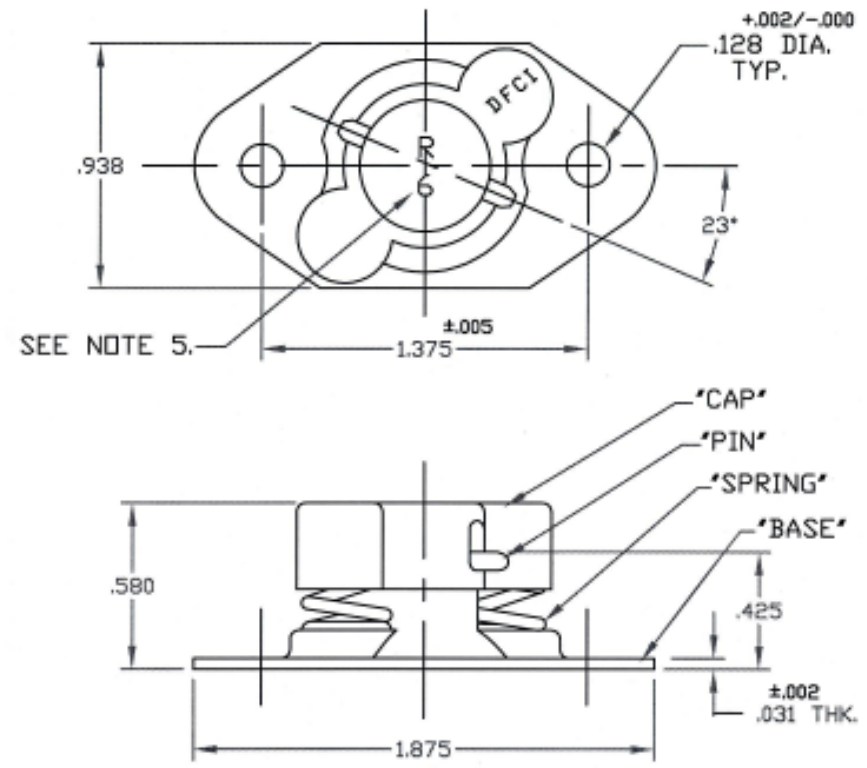

UNCONTROLLED

C2600 SHT. 1 of 2 REV. B

REVISIONS			
SYM	DESCRIPTION	DATE	APPROV
B	CHNG FINISH PER ECN 1090	6-3-08	R.C.



FOR PART NO. REFER TO SHEET 2 of 2.

MAT'L PER NOTE 2.	TOLERANCES ON DIMENSIONS UNLESS OTHERWISE SPECIFIED X* = ±2* .XX = ± .015 X/X = ±1/32 .XXX = ± .010 MACHINE FINISH 125T		 <b>DFCI SOLUTIONS INC.</b> 425 UNION BOULEVARD WEST ISLIP, NEW YORK 11795	
HEAT TREAT PER NOTE 2.	PART NO.	DRN S. Francis	DATE 1-13-05	<b>SU-2300 RECEPTACLE ASSY.</b> <b>2600-18-Z3CT.</b>
FINISH ZINC PLATE PER NOTE 1.		CHK F. Boach	DATE 6-4-08	
		ENG John Colborn	DATE 6-4-08	SIZE A
		MFG D. Hill	DATE 6-4-08	FSCM NO 72794
	NEXT ASSY	USED ON S. Hill	DATE 6-4-08	DWG. NO. C2600
	APPLICATION BLOCK	SALES	DATE	REV. B
				SCALE NTS
				WT.
				SHEET 1 OF 2

DATE: 07/01/06 FORM: DRAWING

UNCONTROLLED

REVISIONS			
SYM	DESCRIPTION	DATE	APPROV
B	CHNG FINISH PER ECN 1090	6-3-08	<i>R.C.</i>

RECEPTACLE ASSY. P/N
2600-18-Z3CT

NOTES:

- FINISH:  
ZINC PLATE PER ASTM-B-633, TYPE III, SC 2, CLEAR TRIVALENT CHROMATE WITH SEALER. (RoHS COMPLIANT) FINISH SUFFIX: -Z3CT  
THE ABOVE MENTIONED FINISH WILL BE SUPPLIED AS THE STANDARD FINISH, UPON DEPLETION OF EXISTING STOCK WHICH ARE FINISHED AS FOLLO: CADMIUM PLATE PER QQ-P-416, TYPE I, CLASS 2, CLEAR CHROMATE. FINISH SUFFIX -C3C.
- MATERIAL:  
‘BASE’ S.A.E 4130 STEEL, HEAT TREAT TO ROCKWELL C37-40.  
‘PIN’ & ‘SPRING’ STEEL MUSIC WIRE.  
‘CAP’ PER S.A.E 1008/1010 STEEL.
- FOR THE APPLICATION OF ALTERNATIVE FINISHES, REMOVE SUFFIX -Z3CT FROM THE PART NO. AND ADD THE REQUIRED FINISH TO THE PART NO. SUFFIX. ‘EXAMPLE FOR BLACK ZINC TRIVALENT CHROMATE FINISH, THE PART NO. IS 2600-18-Z3BT
- PART WILL BE MARKED AS SHOWN ( R 6 ) UNTILL DEPLETION OF EXISTING STOCK. THEREAFTER PART WILL BE MARKED WITH FOLLOWING DESIGNATION ‘ 6 ‘.
- PLEASE VISIT WWW.DFCIS.COM/C2600 FOR A LIST OF AVAILABLE FINISHES.

MATL PER NOTE 2.	TOLERANCES ON DIMENSIONS UNLESS OTHERWISE SPECIFIED X = ±2" .XX = ±.015 X/X = ±1/32 .XXX = ±.010		MACHINE FINISH <i>1257</i>		 <b>DFCI SOLUTIONS INC.</b> 425 UNION BOULEVARD WEST ISLIP, NEW YORK 11795	
HEAT TREAT PER NOTE 2.	PART NO.	DRN <i>S. Fennois</i>	DATE 1-13-05	<b>SU-2300 RECEPTACLE ASSY.</b> <b>2600-18-Z3CT.</b>		
FINISH ZINC PLATE PER NOTE 1.		CHK <i>F. Borich</i>	DATE 6-4-08			
		ENG <i>Mark Carlson</i>	DATE 6-4-08	SIZE A	FSCM NO 72794	DWG. NO. C2600
		MFG <i>Bill [unclear]</i>	DATE 6-4-08	SCALE NTS	WT.	REV. B
	NEXT ASSY	USED ON	DATE	SHEET 2 OF 2		
	APPLICATION BLOCK	SALES	DATE			

DATE: 07/01/06 FORM: DRAWING