

UNCONTROLLED

C2601 SHT. 1of2 REV. c

REVISIONS			
SYM	DESCRIPTION	DATE	APPROV
C	CHNG FINISH PER ECN 1093	7-8-08	R.C.

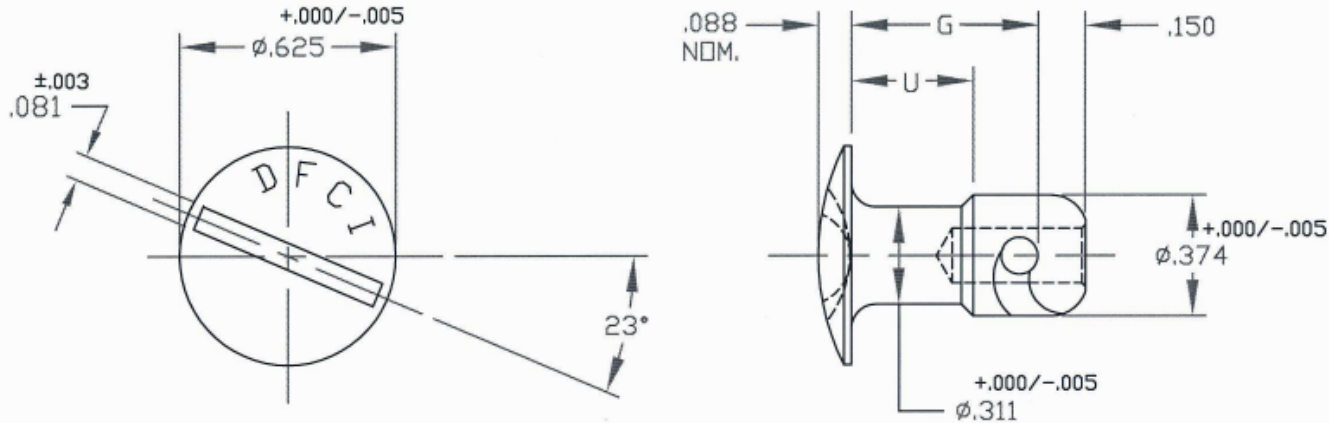

FOR PART NO. REFER TO SHEET 2 of 2.

MAT'L A.I.S.I 8620 STEEL, TYPE 303 OR 17-4PH ST. STEEL.		TOLERANCES ON DIMENSIONS UNLESS OTHERWISE SPECIFIED $X^* = \pm 2^*$.XX = $\pm .015$ $X/X = \pm 1/32$.XXX = $\pm .010$ MACHINE FINISH 125		DFCI SOLUTIONS INC. 425 UNION BOULEVARD WEST ISLIP, NEW YORK 11795	
HEAT TREAT PER NOTE 2.		PART NO.	DRN S. FRANCIS DATE 12-21-04	TITLE SU-2300 LINE STUD, 2601-20-xx-Z3CT.	
FINISH PER NOTE 1.		CHK F. BARD DATE 7-14-08	ENG W. COLON DATE 7-14-08	SIZE A	FSCM NO 72794
<small>THE FASTENER PARTS SHOWN ON THIS PRINT ARE PROPRIETARY ARTICLES TO WHICH DFCI SOLUTIONS INC. RETAINS THE EXCLUSIVE RIGHTS OF MANUFACTURE, USE AND SALE. THE PRINT OR DRAWING IS SUBMITTED IN CONFIDENCE AND DOES NOT CONVEY A LICENSE OR PERMISSION TO MANUFACTURE THE FASTENER OR FASTENER PARTS.</small>		MFG B. HILDEBRAND DATE 7-15-08	QC B. HILDEBRAND DATE 7-15-08	DWG. NO. C2601	REV. C
DATE: 07/01/06 FORM: DRAWING		APPLICATION BLOCK		SCALE NTS	WT.
				SHEET 1 OF 2	

The parts shown in this print are proprietary articles to which DFCI Solutions, Inc. retains the exclusive rights of manufacture, use and sale. The print or drawing is submitted in confidence and does not convey a license or permission to manufacture the parts. Copyright © 2010 by DFCI Solutions, Inc. All rights reserved.

UNCONTROLLED

REVISIONS			
SYM	DESCRIPTION	DATE	APPROV
C	CHNG FINISH PER ECN 1093	7-8-08	P.C.

PART NO. (STEEL STUD)	G	U
2601-20-5-Z3CT	.410	.180
2601-20-8-Z3CT	.440	.230
2601-20-11-Z3CT	.470	.280
2601-20-14-Z3CT	.500	
2601-20-17-Z3CT	.530	.330
2601-20-20-Z3CT	.560	
2601-20-23-Z3CT	.590	.380
2601-20-26-Z3CT	.620	.430
2601-20-29-Z3CT	.650	
2601-20-32-Z3CT	.680	.480
2601-20-35-Z3CT	.710	
2601-20-38-Z3CT	.740	.530
2601-20-41-Z3CT	.770	.580
2601-20-44-Z3CT	.800	
2601-20-47-Z3CT	.830	.630
2601-20-50-Z3CT	.860	
2601-20-53-Z3CT	.890	.680
2601-20-56-Z3CT	.920	.730
2601-20-59-Z3CT	.950	
2601-20-62-Z3CT	.980	.780
2601-20-65-Z3CT	1.010	
2601-20-68-Z3CT	1.040	.830
2601-20-71-Z3CT	1.070	.880
2601-20-74-Z3CT	1.100	
2601-20-77-Z3CT	1.130	.930
2601-20-83-Z3CT	1.190	.980
2601-20-89-Z3CT	1.250	.780

NOTES:

- FINISH:
ZINC PLATE PER ASTM-B-633, TYPE III, SC 2, CLEAR TRIVALENT CHROMATE WITH SEALER. (RoHS COMPLIANT) FINISH SUFFIX: -Z3CT
THE ABOVE MENTIONED FINISH WILL BE SUPPLIED AS THE STANDARD FINISH, UPON DEPLETION OF EXISTING STOCK WHICH ARE FINISHED AS FOLLO: CADMIUM PLATE PER QQ-P-416, TYPE I, CLASS 2, CLEAR CHROMATE. FINISH SUFFIX -C3C.
- HEAT TREATMENT:
A: PART MADE OF STEEL, ROCKWELL C30-38.
B: PART MADE OF TYPE 303 ST. STEEL, NOT HEAT TREATED.
C: PART MADE OF 17-4PH ST. STEEL, ROCKWELL C39-43.
- FOR PART NO. STUD MADE FROM TYPE 303 ST. STEEL, REMOVE SUFFIX -Z3CT FROM P/N AND ADD "SS" EXAMPLE 2601-20-5-SS, OR FOR ST. STEEL 17-4PH ADD " 18S " EXAMPLE 2601-20-5-18S."
- FOR THE APPLICATION OF ALTERNATIVE FINISHES, REMOVE SUFFIX -Z3CT FROM THE PART NO. AND ADD THE REQUIRED FINISH TO THE PART NO. SUFFIX. *EXAMPLE FOR BLACK ZINC TRIVALENT CHROMATE FINISH, THE PART NO. IS 2601-20-5-Z3BT.
- PLEASE VISIT WWW.DFCIS.COM/C2601 FOR A LIST OF AVAILABLE FINISHES.

MAT'L A.I.S.I 8620 STEEL, TYPE 303 OR 17-4PH ST. STEEL.		TOLERANCES ON DIMENSIONS UNLESS OTHERWISE SPECIFIED X" = ±2" .XX = ±.015 X/X = ±1/32 .XXX = ±.010 MACHINE FINISH 125		 DFCI SOLUTIONS INC. 425 UNION BOULEVARD WEST ISLIP, NEW YORK 11795	
HEAT TREAT PER NOTE 2.		PART NO.	DRN S. FRANCIS DATE 12-21-04	TITLE SU-2300 LINE STUD, 2601-20-xx-Z3CT.	
FINISH PER NOTE 1.			CHK F. Basile DATE 7-14-08	SIZE A	
<small>THE FASTENER PARTS SHOWN ON THIS PRINT ARE PROPRIETARY ARTICLES TO WHICH DFCI SOLUTIONS INC. RETAINS THE EXCLUSIVE RIGHTS OF MANUFACTURE, USE AND SALE. THE PRINT OR DRAWING IS SUBMITTED IN CONFIDENCE AND DOES NOT CONVEY A LICENSE OR PERMISSION TO MANUFACTURE THE FASTENER OR FASTENER PARTS.</small>			ENG John Corbin DATE 7-14-08	FSCM NO 72794	DWG. NO. C2601
NEXT ASSY		USED ON	MFG DATE 7-14-08	SCALE NTS	WT.
APPLICATION BLOCK		SALES	DATE 7-15-08	REV. C	
DATE: 07/01/06		FORM: DRAWING		SHEET 2 OF 2	