

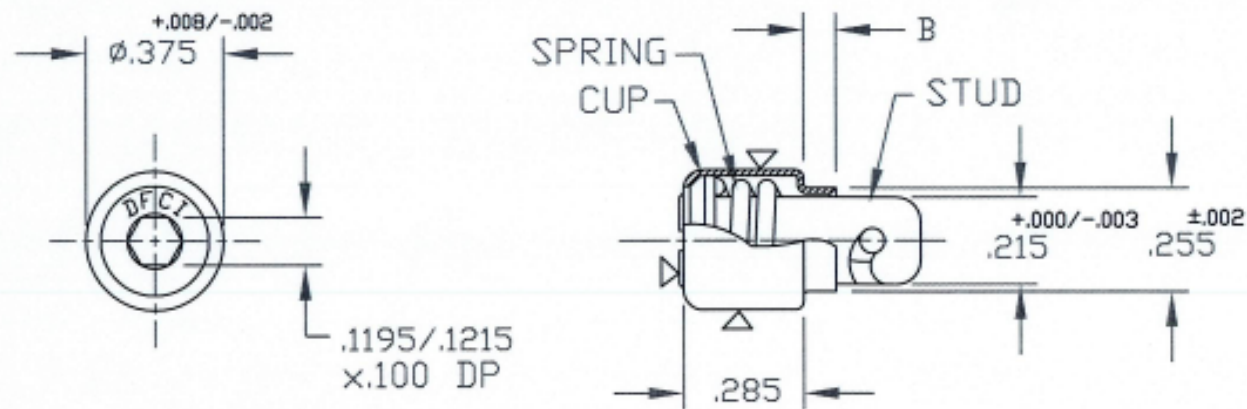

UNCONTROLLED

C3501-241206 SHT. 1 of 2 REV. *d*

REVISIONS			
SYM	DESCRIPTION	DATE	APPROV
C	ADD COC# MFG.DWG. ECN 1069	1-4-08	<i>R. OLSEN</i>



FOR PART NO. REFER TO SHEET 2 of 2

MAT'L PER NOTE 1.	TOLERANCES ON DIMENSIONS UNLESS OTHERWISE SPECIFIED $X^* = \pm 2^*$.XX = $\pm .015$ $X/X = \pm 1/32$.XXX = $\pm .010$ MACHINE FINISH 125T		 DFCI SOLUTIONS INC. 425 UNION BOULEVARD WEST ISLIP, NEW YORK 11795				
HEAT TREAT STUD=ROCKWELL C30 - 38.	PART NO.	DRN <i>S. FRANZ</i>	DATE 12-14-04	PA-3500 LINE, STUD ASSY. 3501-xx-241206-Z3CT			
FINISH PER NOTE 2.		CHK <i>F. Basik</i>	DATE 1-7-08				
<small>THE PARTS AND PARTS SHOWN IN THIS PRINT ARE PROPRIETARY ARTICLES TO WHICH DFCI SOLUTIONS INC. RETAINS THE EXCLUSIVE RIGHTS OF MANUFACTURE, USE AND SALE. THE PRINT OR DRAWING IS SUBMITTED IN CONFIDENCE AND DOES NOT CONVEY A LICENSE OR PERMISSION TO MANUFACTURE THE PARTS OR PARTS THEREOF. COPYRIGHT 2007, DFCI SOLUTIONS INC. ALL RIGHTS RESERVED.</small>		ENG <i>R. OLSEN</i>	DATE 1-7-08	SIZE A			
	NEXT ASSY	USED ON	MFG <i>[Signature]</i>	DATE 1-7-08	FSCM NO. 72794		
	APPLICATION BLOCK	SALES	DATE 1-31-08	DATE 1-31-08	DWG. NO. C3501-241206		
				SCALE NTS	WT.	REV. C	SHEET 1 OF 2

DATE: 07/01/06 FORM: DRAWING

UNCONTROLLED

REVISIONS			
SYM	DESCRIPTION	DATE	APPROV
C	ADD COC# MFG.DWG. ECN 1069	1-4-08	R. OLSEN

NOTES:

- MATERIAL:
 CUP: PER A.I.S.I 1008, 1010, 1012, STEEL .
 STUD: A.I.S.I 4037, 1118, 8620 STEEL.
 SPRING: MUSIC WIRE PER ASTM-A-228 STEEL.
- STANDARD FINISH:
 ZINC PLATE PER ASTM-B-633, TYPE III, SC 2,
 CLEAR TRIVALENT CHROMATE WITH SEALER.
 (RoHS COMPLIANT) FINISH SUFFIX: -Z3CT
 THE ABOVE MENTIONED FINISH WILL BE SUPPLIED
 AS THE STANDARD FINISH
 UPON DEPLETION OF EXISTING STOCK WHICH ARE
 FINISHED AS FOLLOW:
 CADMIUM PLATE PER QQ-P-416, TYPE I, CLASS 2,
 CLEAR CHROMATE. (FINISH SUFFIX: -C3C)

- SPECIAL FINISH BLACK OXIDE OVER COPPER:
 BLACK OXIDE OVER COPPER
 PLATE .0003" TO .0005", WITH DULL BLACK
 OXIDE CONVERSION, AND DULL BLACK
 WAX COATING. FOR PART NO. REMOVE SUFFIX
 -Z3CT AND ADD (-BOC) TO THE PART NO.
 (EXAMPLE 3501-38-241206-BOC)
- SPECIAL FINISH BLACK EPOXY PAINT OVER ZINC:
 ZINC PLATE PER ASTM-B-633, TYPE III, SC 2,
 CLEAR TRIVALENT CHROMATE WITH NO SEALER.
 THEN PAINT WITH BLACK EPOXY PRIMER .0006" MIN.
 AND DULL BLACK EPOXY ENMEL .0003" MIN.
 THE PART NO. SUFFIX: -EEBT.
 (EXAMPLE 3501-38-241206-EEBT)
- WHEN BLACK EPOXY IS APPLIED, ONLY
 SURFACES MARKED WITH ▷ ARE COVERED.
- FOR THE APPLICATION OF ALTERNATIVE FINISHES,
 REMOVE SUFFIX -Z3CT FROM THE PART NO.
 AND ADD THE REQUIRED FINISH TO THE PART NO. SUFFIX.
 *EXAMPLE FOR BLACK ZINC TRIVALENT CHROMATE
 FINISH, THE P/N IS 3501-38-241206-Z3BT*.
- PLEASE VISIT WWW.DFCIS.COM/C3501-241206 FOR
 A LIST OF AVAILABLE FINISHES.

STUD ASSY. PART NO.	PANEL THICKNESS RANGE	B DIM
3501-38-241206-Z3CT	.060 - .069	.080
3501-41-241206-Z3CT	.090 - .099	.110
3501-43-241206-Z3CT	.110 - .119	.130
3501-44-241206-Z3CT	.120 - .129	.140

MATERIAL PER NOTE 1.		TOLERANCES ON DIMENSIONS UNLESS OTHERWISE SPECIFIED X* = ±2" .XX = ±.015 X/X = ±1/32 .XXX = ±.010		MACHINE FINISH 125T		 DFCI SOLUTIONS INC. 425 UNION BOULEVARD WEST ISLIP, NEW YORK 11795	
HEAT TREAT STUD=ROCKWELL C30 - 38.		PART NO.	DRN	DATE	PA-3500 LINE, STUD ASSY. 3501-xx-241206-Z3CT		
FINISH PER NOTE 2.			S. FRANCIS	12-14-04	FSCM NO		
			F. Basil	7-7-08	DWG. NO.		
			R. OLSEN	1/7/08	C3501-241206		
			B. Hilde	1/11/08	SIZE	REV.	
NEXT ASSY		USED ON	SALES	DATE	A	C	
APPLICATION BLOCK					72794		
DATE: 07/01/06		FORM: DRAWING			SCALE	SHEET	
					NTS	2 OF 2	