

UNCONTROLLED

C3501-241832 REV. D

REVISIONS			
SYM	DESCRIPTION	DATE	APPROV
D	ASSY CHNGS PER ENC 959	5-8-06	<i>P. OLSON</i>

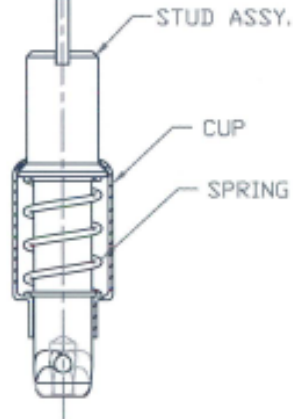
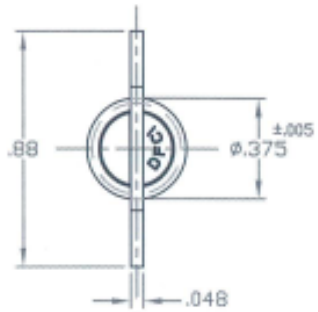

STUD ASSY. P/N
3501-73-241832

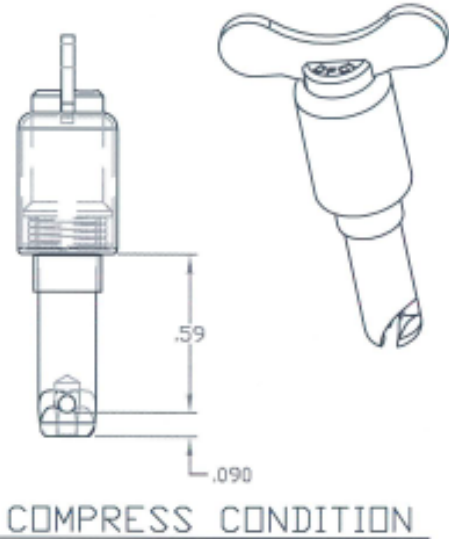
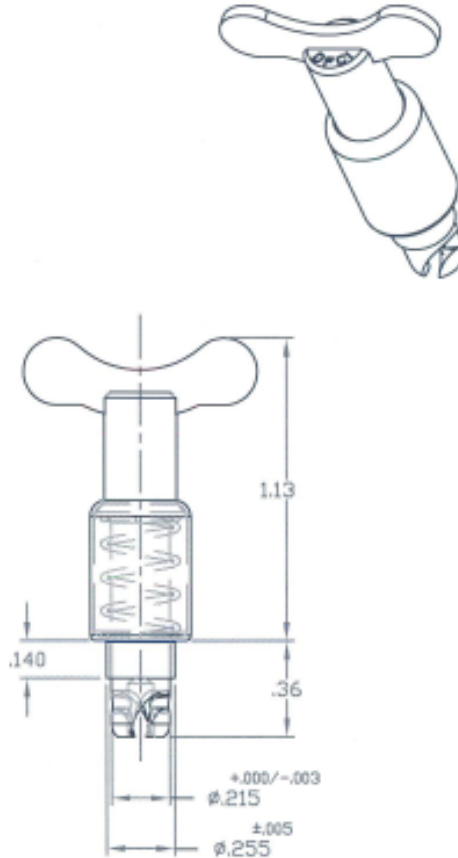

MATT'L PER NOTE 1 ON SHEET 2 of 2.		TOLERANCES ON DIMENSIONS UNLESS OTHERWISE SPECIFIED X' = ±1/2" .XX = ±.015 CONCENTRICITY F.I.M. .005 X/X = ±1/32 .XXX = ±.010 MACHINE FINISH 125/		DFCI SOLUTIONS INC. 425 UNION BOULEVARD WEST ISLIP, NEW YORK 11795	
HEAT TREAT NONE.		PART NO.	DRN <i>S. FRANGES</i> DATE 11-21-05	PA-3500 LINE STUD ASSY. 3501-73-241832	
FINISH CLEAN & FREE OF BURRS.			CHK <i>J. Baird</i> DATE 5/9/06	SIZE A	FSCM NO 72794
<small>THE FASTENER PARTS SHOWN IN THIS PRINT ARE PROPRIETARY ARTICLES TO WHICH DFCI SOLUTIONS INC. RETAINS THE EXCLUSIVE RIGHTS OF MANUFACTURE, USE AND SALE. THE PRINT OR DRAWING IS SUBMITTED IN CONFIDENCE AND DOES NOT CONVEY A LICENSE OR PERMISSION TO MANUFACTURE THE FASTENER OR FASTENER PARTS. © COPYRIGHT 2006, DFCI SOLUTIONS INC. ALL RIGHTS RESERVED. DATE: 11/01/03 FORM: DRAWING</small>			ENG <i>P. OLSON</i> DATE 5/9/06	DWG. NO. C3501-241832	REV. D
		NEXT ASSY	USED ON	MFG <i>JS</i> DATE 5/9/06	SCALE NTS
APPLICATION BLOCK		SALES	DATE	SHEET 1 OF 2	

The parts shown in this print are proprietary articles to which DFCI Solutions, Inc. retains the exclusive rights of manufacture, use and sale. The print or drawing is submitted in confidence and does not convey a license or permission to manufacture the parts. Copyright © 2006 by DFCI Solutions, Inc. All rights reserved.

UNCONTROLLED

C3501-241832 REV. D

REVISIONS			
SYM	DESCRIPTION	DATE	APPROV
D	ASSY CHNGS PER ENC 959	5-8-06	R. OLESOW

NOTES:

- MATERIAL:
 CUP: TYPE 303 STAINLESS STEEL.
 STUD: TYPE 303 STAINLESS STEEL.
 SPRING: TYPE 302 ST. STEEL, SPRING TEMPER.
 WING: TYPE 302 STAINLESS STEEL.
- STUD MUST ENGAGE 3518-B RECEPTACLE WHEN MOUNTED IN THE COVER (PANEL) WHICH IS .400 THICK.

STUD ASSY. P/N
3501-73-241832

MAT'L PER NOTE 1.	TOLERANCES ON DIMENSIONS UNLESS OTHERWISE SPECIFIED X* = ±1/2" .XX = ±.015 CONCENTRICITY F.I.M. .005 X/X = ±1/32 .XXX = ±.010 MACHINE FINISH 125/		 DFCI SOLUTIONS INC. 425 UNION BOULEVARD WEST ISLIP, NEW YORK 11795	
HEAT TREAT NONE.	PART NO.	DRN S. F. RAVES DATE 11-21-05	PA-3500 LINE STUD ASSY. 3501-73-241832	
FINISH CLEAN & FREE OF BURRS.		CHK F. Basil DATE 5-9-06	SIZE A	FSCM NO 72794
<small>THE FASTENER PARTS SHOWN IN THIS PRINT ARE PROPRIETARY ARTICLES TO WHICH DFCI SOLUTIONS INC. RETAINS THE EXCLUSIVE RIGHTS OF MANUFACTURE, USE AND SALE. THE PRINT OR DRAWING IS SUBMITTED IN CONFIDENCE AND DOES NOT CONVEY A LICENSE OR PERMISSION TO MANUFACTURE THE FASTENER OR FASTENER PARTS. © COPYRIGHT 2006, DFCI SOLUTIONS INC. ALL RIGHTS RESERVED.</small>		ENG R. OLESOW DATE 5/9/06	DWG. NO. C3501-241832	REV. D
	NEXT ASSY	USED ON	QC B. Hildebrand DATE 5/19/06	
	APPLICATION BLOCK	SALES	DATE	SCALE NTS

DATE: 11/01/03 FORM: DRAWING