

UNCONTROLLED

C3501-241839 SHT 1of2 REV. C

REVISIONS			
SYM	DESCRIPTION	DATE	APPROV
C	CHANGE WING THICKNESS FROM .048 TO .060 PER ECN 1072	12-4-07	R. OLSEN

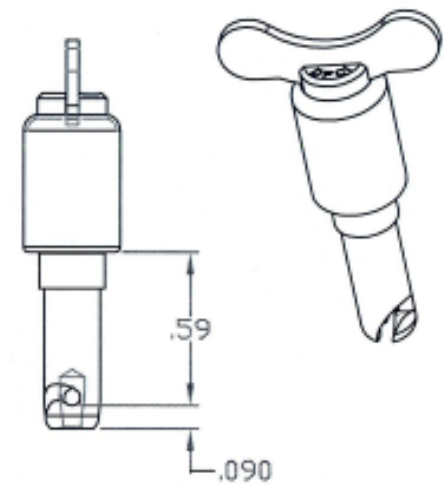
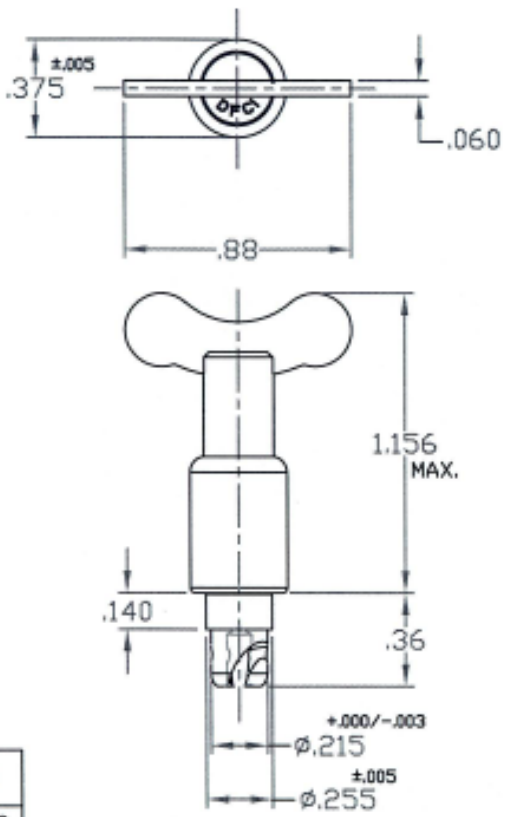

COMPRESS CONDITION

STUD ASSY. P/N  
3501-73-241839-SS

MATL PER NOTE 1 ON SHEET 2.	TOLERANCES ON DIMENSIONS UNLESS OTHERWISE SPECIFIED X = ±2' .XX = ± .015 X/X = ±1/32 .XXX = ± .010		MACHINE FINISH 125T		<b>DFCI SOLUTIONS INC.</b> 425 UNION BOULEVARD WEST ISLIP, NEW YORK 11795	
HEAT TREAT AS NOTED.	PART NO.	DRN S. F	DATE 8-8-06	FILE PA-3500 ST ST STUD ASSY.		
FINISH CLEAN & FREE OF BURRS.		CHK Z. Basil	DATE 12-4-07	3501-73-241839-SS	REV. C	
<small>THE PARTS SHOWN ON THIS PRINT ARE PROPRIETARY ARTICLES TO WHICH DFCI SOLUTIONS, INC. RETAINS THE EXCLUSIVE RIGHTS OF MANUFACTURE, USE AND SALE. THE PRINT OR DRAWING IS SUBMITTED IN CONFIDENCE AND DOES NOT CONVEY A LICENSE OR PERMISSION TO MANUFACTURE THE PARTS OR PARTS THEREOF.</small> <small>© COPYRIGHT 2003, DFCI SOLUTIONS INC. ALL RIGHTS RESERVED.</small>	NEXT ASSY	USED ON	DATE 12/4/07	SIZE A	FSCM NO 72794	
	APPLICATION BLOCK	SALES	DATE 12/4/07	DWG. NO. C3501-241839	SCALE NTS	WT.
DATE: 07/01/06	FORM: DRAWING					SHEET 1 OF 2

The parts shown in this print are proprietary articles to which DFCI Solutions, Inc. retains the exclusive rights of manufacture, use and sale. The print or drawing is submitted in confidence and does not convey a license or premission to manufacture the parts. Copyright © 2007 by DFCI Solutions, Inc. All rights reserved.

UNCONTROLLED

REVISIONS			
SYM	DESCRIPTION	DATE	APPROV
C	CHANGE WING THICKNESS FROM .048 TO .060 PER ECN 1072	12-4-07	<i>R. Basil</i>

NOTES:

- MATERIAL:  
 CUP: TYPE 303 STAINLESS STEEL.  
 STUD: TYPE 303 STAINLESS STEEL.  
 SPRING: TYPE 17-7PH ST. STEEL, SPRING TEMPER.  
 WING: TYPE 302 STAINLESS STEEL.
- STUD MUST ENGAGE 3518-B RECEPTACLE WHEN MOUNTED IN THE COVER (PANEL) WHICH IS .400 THICK.

MAT'L PER NOTE 1	TOLERANCES ON DIMENSIONS UNLESS OTHERWISE SPECIFIED $X^* = \pm 2^*$ .XX = $\pm .015$ $X/X = \pm 1/32$ .XXX = $\pm .010$ MACHINE FINISH 125		 <b>DFCI SOLUTIONS INC.</b> 425 UNION BOULEVARD WEST ISLIP, NEW YORK 11795	
HEAT TREAT AS NOTED.	PART NO.	DRN S. F	DATE 8-8-06	PA-3500 ST ST STUD ASSY. 3501-73-241839-SS
FINISH CLEAN & FREE OF BURRS.		CHK <i>F. Basil</i>	DATE 12-4-07	
<small>THE FASTENER PARTS SHOWN ON THIS PRINT ARE PROPRIETARY ARTICLES TO WHICH DFCI SOLUTIONS INC. RETAINS THE EXCLUSIVE RIGHTS OF MANUFACTURE, USE AND SALE. THE PRINT OR DRAWING IS SUBMITTED IN CONFIDENCE AND DOES NOT CONVEY A LICENSE OR PERMISSION TO MANUFACTURE THE FASTENER OR FASTENER PARTS.                  © COPYRIGHT 2003, DFCI SOLUTIONS INC. ALL RIGHTS RESERVED.</small>		ENG <i>R. OLBSON</i>	DATE 12/4/07	DWG. NO. C3501-241839 REV. C
	NEXT ASSY	USED ON	MPD <i>R. OLBSON</i>	
	APPLICATION BLOCK	SALES	DATE	SIZE A FSCM NO 72794 SCALE NTS WT. SHEET 2 OF 2

DATE: 07/01/08 FORM: DRAWING