

C3501-241846 REV. 4

UNCONTROLLED

REVISIONS			
SYM	DESCRIPTION	DATE	APPROV
A	INITIAL RELEASE PER ECN 845	9-8-08	R.C.

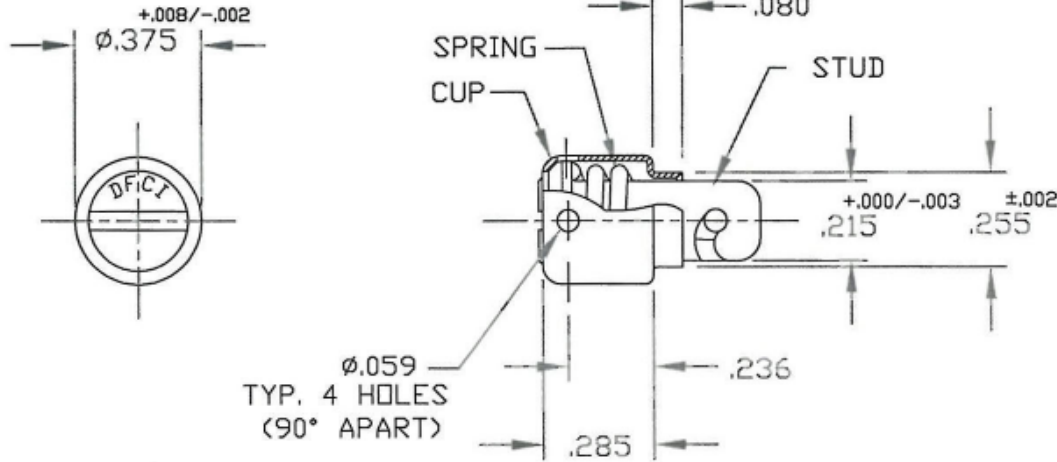

STUD ASSY.  
PART NO.  
3501-38-241846-C3C

NOTES:

- MATERIAL:  
CUP: PER A.I.S.I 1008, 1010, 1215 DR 8620 STEEL.  
STUD: PER A.I.S.I 4037, C1118, 1117 DR 8620 STEEL  
SPRING: MUSIC WIRE PER ASTM-A-228 STEEL.
- FINISH: CUP, STUD AND SPRING:  
CADMIUM PLATE PER QQ-P-416,  
TYPE I, CLASS 2, CLEAR CHROMATE.

MATL PER NOTE 1.	TOLERANCES ON DIMENSIONS UNLESS OTHERWISE SPECIFIED X° = ±2° .XX = ±.015 X/X = ±1/32 .XXX = ±.010 MACHINE FINISH 125/T		<b>DFCI SOLUTIONS INC.</b> 425 UNION BOULEVARD WEST ISLIP, NEW YORK 11795	
HEAT TREAT STUD=ROCKWELL C30 - 38.	PART NO.	DRN S. FRANKS	DATE 9-8-08	TITLE <b>PA-3500 LINE, STUD ASSY.</b> <b>3501-38-241846-C3C.</b>
FINISH PER NOTE 2.		CHK F. Basile	DATE 9-8-08	
		ENG Josh Colburn	DATE 9-8-08	SIZE FSCM NO DWG. NO. REV. A 72794 C3501-241846 A
		MFG [Signature]	DATE 9-8-08	
	NEXT ASSY USED ON	SALES	DATE	SCALE NTS WT. SHEET 1 OF 1

DATE: 07/01/06 FORM: DRAWING