

UNCONTROLLED

C3501-241851 REV. A

REVISIONS			
SYM	DESCRIPTION	DATE	APPROV
A	INITIAL RELEASE PER ECN 845	9-9-08	R.C

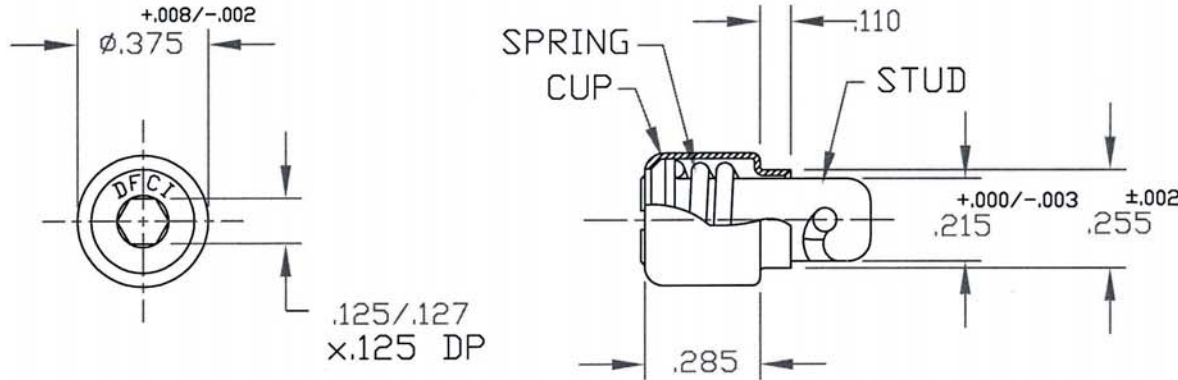

NOTES:

- MATERIAL:
 CUP: PER A.I.S.I 1008, 1010, 1215 OR 8620 STEEL.
 STUD: PER A.I.S.I 4037, C1118, 1117 OR 8620 STEEL
 SPRING: MUSIC WIRE PER ASTM-A-228 STEEL.
- FINISH: CUP, STUD & SPRING:
 ZINC PLATE PER ASTM-B-633, TYPE III, SC 2,
 CLEAR TRIVALENT CHROMATE WITH SEALER.
 (RoHS COMPLIANT) FINISH SUFFIX: -Z3CT.

STUD ASSY.
 PART NO.
 3501-41-241851-Z3CT

MATL PER NOTE 1.	TOLERANCES ON DIMENSIONS UNLESS OTHERWISE SPECIFIED $X^{\circ} = \pm 2^{\circ}$.XX $\pm .015$ $X/X = \pm 1/32$.XXX $\pm .010$ MACHINE FINISH 125T		 DFCI SOLUTIONS INC. 425 UNION BOULEVARD WEST ISLIP, NEW YORK 11795	
HEAT TREAT STUD=ROCKWELL C30 - 38.	PART NO.	DRN S. Frazzetta DATE 9-9-08	DATE 9-10-08 PA-3500 LINE, STUD ASSY. 3501-41-241851-Z3CT	
FINISH PER NOTE 2.		CHK F. Basile DATE 9-10-08	SIZE A	FSCM NO 72794
<small>THE FASTENER PARTS SHOWN IN THIS PRINT ARE PROPRIETARY ARTICLES TO WHICH DFCI SOLUTIONS INC. RETAINS THE EXCLUSIVE RIGHTS OF MANUFACTURE, USE AND SALE. THE PRINT OR DRAWING IS SUBMITTED IN CONFIDENCE AND DOES NOT CONVEY A LICENSE OR PERMISSION TO MANUFACTURE THE FASTENER OR FASTENER PARTS.</small> © COPYRIGHT 2003, DFCI SOLUTIONS INC. ALL RIGHTS RESERVED. DATE: 07/01/06 FORM: DRAWING	NEXT ASSY	USED ON	DWG. NO. C3501-241851	REV. A
	APPLICATION BLOCK	SALES	SCALE NTS	WT.
			SHEET 1 OF 1	