

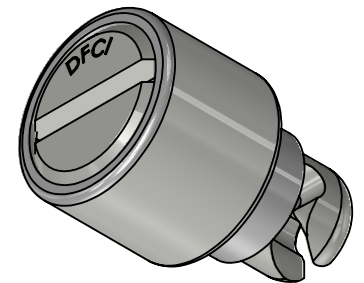

- NOTES:**
- MATERIAL:**
 STUD: 8620 OR 4037 STEEL
 SPRING: MUSIC WIRE PER ASTM-A-228
 CUP: A.I.S.I. 1008, 1010, 1215, OR 8620 STEEL
 - HEAT TREAT:**
 STUD: ROCKWELL C30 - 38
 - FINISH:**
 BLACK OXIDE OVER COPPER WITH CLEAR ACRYLIC DIP SEALER PER MIL-C-14550 CLASS2 AND AMS 2418 TYPE 1

REVISIONS			
SYS	DESCRIPTION	DATE	APPROV
/	INITIAL RELEASE	07/22/14	

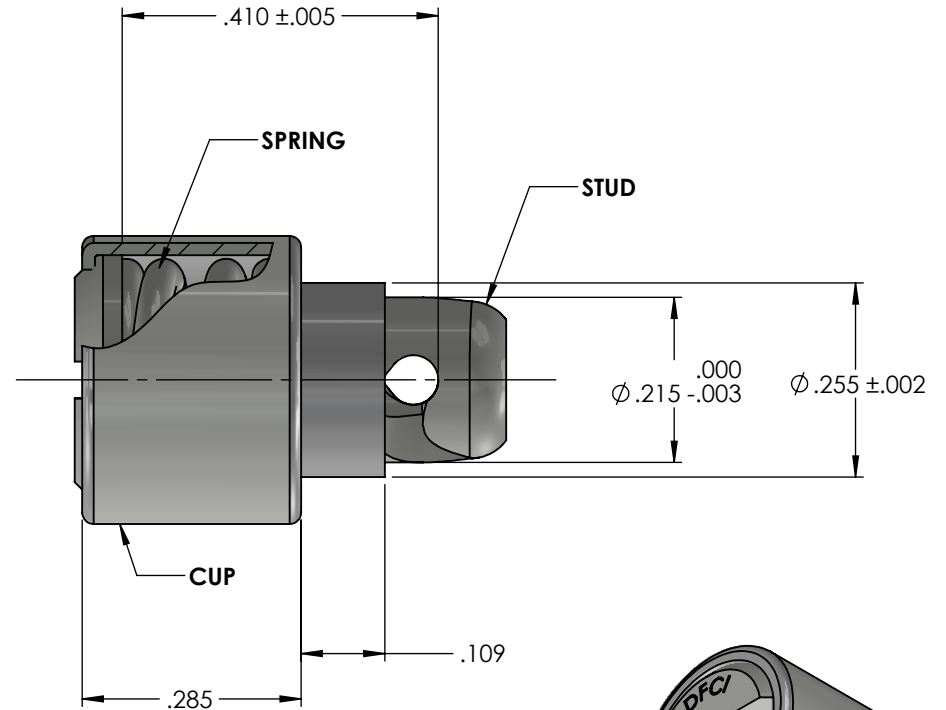
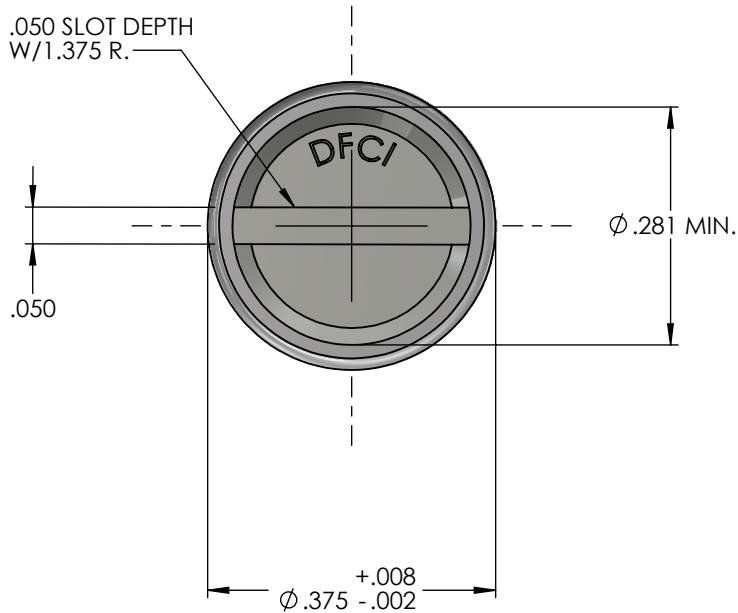

UNCONTROLLED

MATERIAL:	NOTED	TOLERANCES ON DIMENSIONS UNLESS OTHERWISE SPECIFIED				 <p>DFCI SOLUTIONS INC. 425 UNION BOULEVARD. WEST ISLIP, NEW YORK 11795</p>
HEAT TREAT:	NOTED	X° = ±2°	.XX = ±.015	MACHINE FINISH = .125		
FINISH:	NOTED	X/X = ±1/32	.XXX = ±.010			
THE FASTENER PARTS SHOWN IN THIS PRINT ARE PROPRIETARY ARTICLES TO WHICH DFCI SOLUTIONS INC., RETAINS THE EXCLUSIVE RIGHTS OF MANUFACTURE, USE AND SALE. THE PRINT OR DRAWING IS SUBMITTED IN CONFIDENCE AND DOES NOT CONVEY A LICENSE OR PERMISSION TO MANUFACTURE THE FASTENER OR FASTENER PARTS.		PART NO.	DRN	DATE	TITLE	
(C) COPYRIGHT 2009, DFCI SOLUTIONS INC. ALL RIGHTS RESERVED.		3501-41-241563-BOC	Frank Basile	07/22/14	PA-3500 STUD ASSEMBLY 3501-41-241563-BOC	
NEXT ASSY	USED ON	G.C.	DATE	DATE	SIZE	
		SALES.	DATE	DATE	FSCM NO.	
					72794	
					DWG. NO.	
					C3501-41-241563	
					REV.	
					/	
APPLICATION BLOCK			SCALE: NTS	WEIGHT:	SHEET 1 OF 1	