

UNCONTROLLED

C3502 REV. C

REVISIONS			
SYM	DESCRIPTION	DATE	APPROV
C	ADD P/N-2-SS PER ECN 1121	12-17-08	<i>FJB</i>

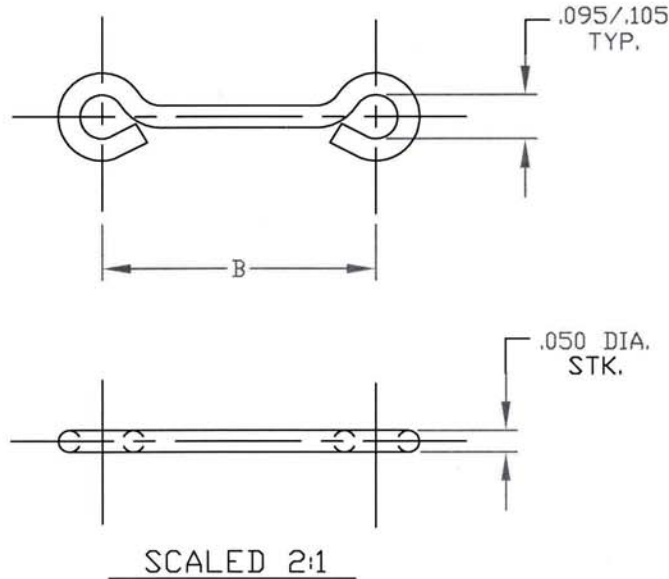

NOTES:

- MATERIAL:
17-7PH COND. C. ST. STEEL PER AMS-5678,
THEN HARDENED TO ROCKWELL C39 - 43.
OR
17-7PH COND. A. ST. STEEL PER AMS-5678,
THEN HARDENED TO TH1050 C38 MIN.
- FINISH: NICKEL FLASH PER QQ-N-290,
CL. I & CADMIUM PLATE PER QQ-P-416,
TYPE I, CLASS 2, CLEAR CHROMATE.

PART NO.	FINISH	B
3502-SS	NATURAL	.625
3502-1-SS-C3NC	PER NOTE 2	
3502-2-SS	NATURAL	1.000

MAT'L PER NOTE 1.	TOLERANCES ON DIMENSIONS UNLESS OTHERWISE SPECIFIED X° = ±2° .XX = ±.015 X/X = ±1/32 .XXX = ±.010 MACHINE FINISH 125		DFCI SOLUTIONS INC. 425 UNION BOULEVARD WEST ISLIP, NEW YORK 11795			
HEAT TREAT PER NOTE 1.	PART NO.	DRN <i>S. Franas</i>	DATE 12-14-04	FILE - 3500 ONE HOLE RECPTCLE. 3502-SS.		
FINISH PER NOTE 2.		CHK <i>F. Basile</i>	DATE 12-12-08			
<small>THE FASTENER PARTS SHOWN IN THIS PRINT ARE PROPRIETARY ARTICLES TO WHICH DFCI SOLUTIONS INC. RETAINS THE EXCLUSIVE RIGHTS OF MANUFACTURE, USE AND SALE. THE PRINT OR DRAWING IS SUBMITTED IN CONFIDENCE AND DOES NOT CONVEY A LICENSE OR PERMISSION TO MANUFACTURE THE FASTENER OR FASTENER PARTS.</small>		ENG <i>S. Kilduff</i>	DATE 12-17-08	SIZE A 72794		
		MFG <i>B. M...</i>	DATE 12-17-08		DWG. NO. C3502	
		NEXT ASSY	USED ON	DATE 12-17-08	REV. C	
<small>© COPYRIGHT 2003, DFCI SOLUTIONS INC. ALL RIGHTS RESERVED.</small> DATE: 07/01/06 FORM: DRAWING		APPLICATION BLOCK	SALES	SCALE NTS	WT.	SHEET 1 OF 1