

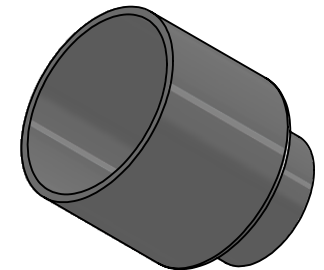

- NOTES:**
1. FINISH:  
ZINC PLATE PER ASTM-B-633, TYPE III, SC2 CLEAR TRIVALENT CHROMATE WITH SEALER.
  2. FOR THE APPLICATION OF ALTERNATIVE FINISHES, REMOVE THE SUFFIX -Z3CT FROM THE PART NUMBER AND ADD THE REQUIRED FINISH SUFFIX TO THE PART NUMBER. EXAMPLE: FOR YELLOW ZINC TRIVALENT CHROMATE FINISH, THE PART NUMBER WOULD BE 3503-24547-5-Z3YT
  3. PLEASE VISIT [www.dfci.com/c3503-24547](http://www.dfci.com/c3503-24547) FOR A LIST OF AVAILABLE FINISHES.
  4. FOR THE PART NUMBER OF A CUP MADE FROM TYPE 303 STAINLESS STEEL, REMOVE SUFFIX -Z3CT AND ADD -SS TO THE PART NUMBER. EXAMPLE: 3503-24547-5-SS

REVISIONS			
SYS	DESCRIPTION	DATE	APPROV
J	PER ECN 1177	01/15/10	FB

PART NO	"A"	"B"
3503-24547-Z3CT	.630	.132
3503-24547-1-Z3CT	.755	.140
3503-24547-2-Z3CT	.755	.080
3503-24547-5-Z3CT	.406	.090
3503-24547-6-Z3CT	.297	.109
3503-24547-7-Z3CT	.297	.190
3503-24547-8-Z3CT	.688	.090
3503-24547-9-Z3CT	.297	.266
3503-24547-11-Z3CT	.297	.220
3503-24547-12-Z3CT	.297	.140
3503-24547-13-Z3CT	.297	.282
3503-24547-15-Z3CT	.389	.080
3503-24547-16-Z3CT	.630	.062
3503-24547-17-Z3CT	.297	.160
3503-24547-19-Z3CT	.409	.140
3503-24547-20-Z3CT	.460	.282

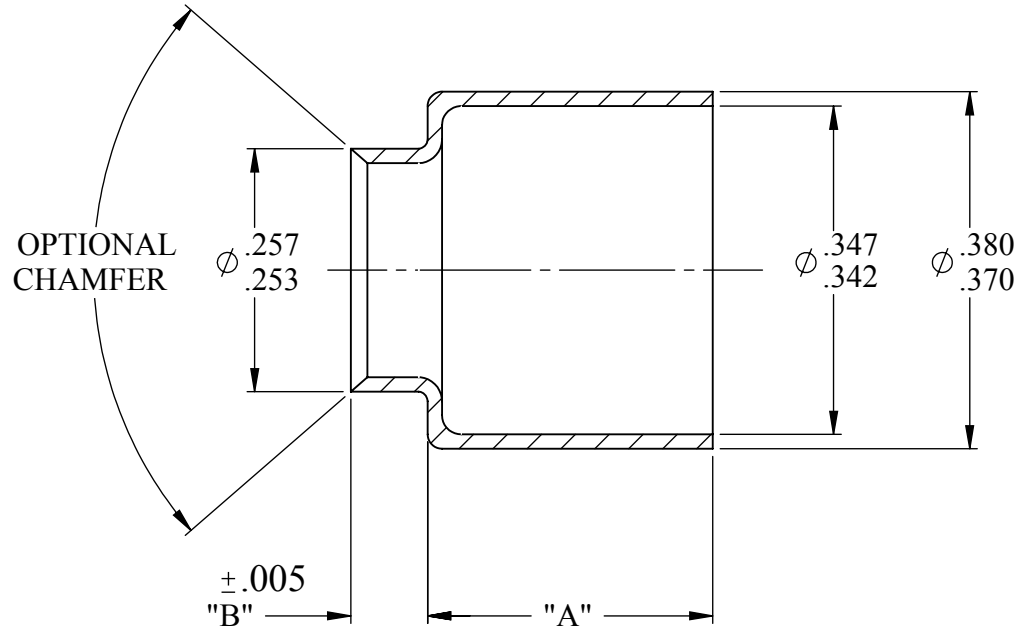

**UNCONTROLLED**

MATERIAL: A.I.S.I 1008, 1010, 1215, 8620 STEEL OR TYPE 303 ST. STEEL (SEE NOTE 4)		TOLERANCES ON DIMENSIONS UNLESS OTHERWISE SPECIFIED X* = $\pm 2^\circ$ .XX = $\pm .015$ X/X = $\pm 1/32$ .XXX = $\pm .010$ MACHINE FINISH = 125				 <b>DFCI SOLUTIONS INC.</b> 425 UNION BOULEVARD. WEST ISLIP, NEW YORK 11795	
HEAT TREAT: /		PART NO. SEE TABLE	DRN Frank Basile	DATE 01/15/10	TITLE PA-3500 LINE CUP 3503-24547-xx-Z3CT SIZE A FSCM NO 72794 DWG. NO. C3503-24547 REV. J SCALE: NTS WEIGHT: SHEET 1 OF 1		
FINISH: SEE NOTES 1, 2, AND 3			CHK. Frank Basile	DATE 01/15/10			
THE FASTENER PARTS SHOWN IN THIS PRINT ARE PROPRIETARY ARTICLES TO WHICH DFCI SOLUTIONS INC., RETAINS THE EXCLUSIVE RIGHTS OF MANUFACTURE, USE AND SALE. THE PRINT OR DRAWING IS SUBMITTED IN CONFIDENCE AND DOES NOT CONVEY A LICENSE OR PERMISSION TO MANUFACTURE THE FASTENER OR FASTENER PARTS. (C) COPYRIGHT 2009, DFCI SOLUTIONS INC. ALL RIGHTS RESERVED.			ENG. Peter Altkorn	DATE 01/15/10			
			MFG. Radu Leban	DATE 01/15/10			
			G.C. Peter Altkorn	DATE 01/15/10			
NEXT ASSY USED ON APPLICATION BLOCK		SALES.	DATE				