

REVISIONS			
SYS	DESCRIPTION	DATE	APPROV
B	PER ECN 1168 & 1249	02/24/10	FB

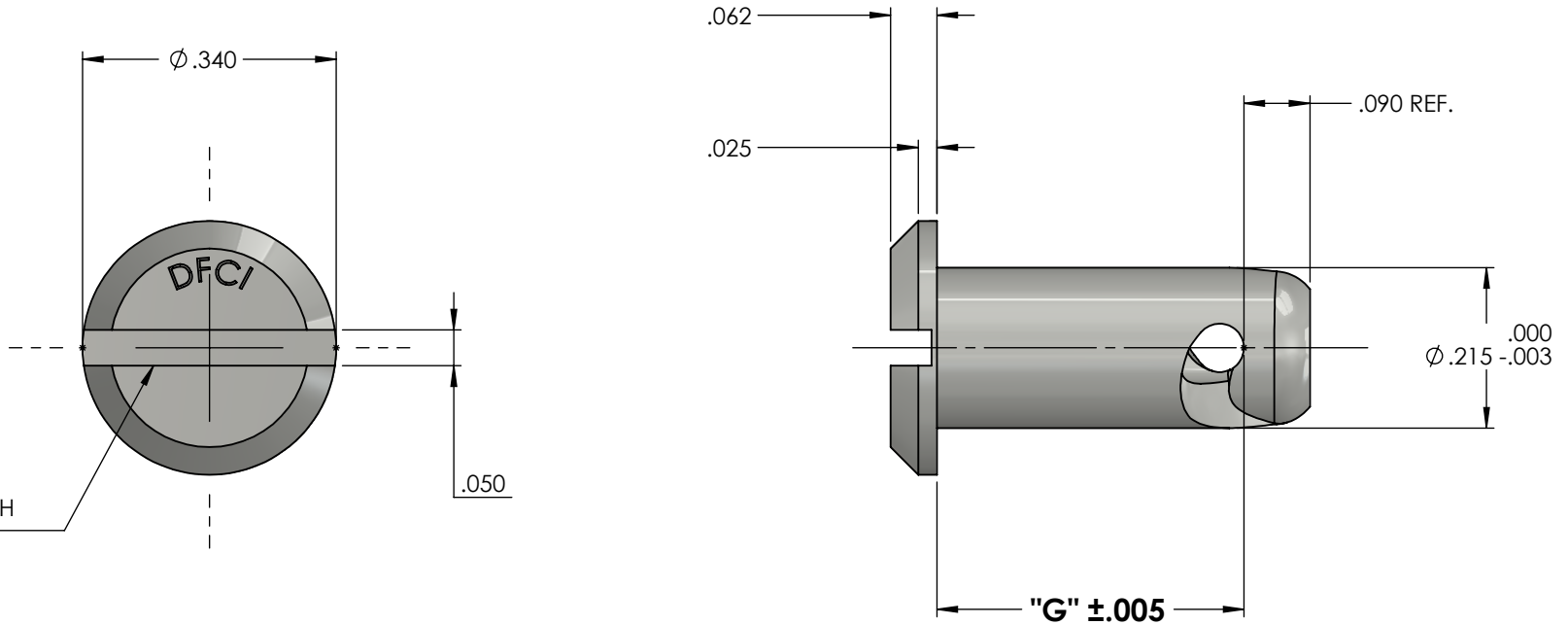

UNCONTROLLED

MATERIAL:	A.I.S.I 8620, 4037 STEEL OR TYPE 303 STAINLESS STEEL
HEAT TREAT:	SEE NOTE 1
FINISH:	SEE NOTE 2
<small>THE FASTENER PARTS SHOWN IN THIS PRINT ARE PROPRIETARY ARTICLES TO WHICH DFCI SOLUTIONS INC., RETAINS THE EXCLUSIVE RIGHTS OF MANUFACTURE, USE AND SALE. THE PRINT OR DRAWING IS SUBMITTED IN CONFIDENCE AND DOES NOT CONVEY A LICENSE OR PERMISSION TO MANUFACTURE THE FASTENER OR FASTENER PARTS.</small>	
<small>(C) COPYRIGHT 2009, DFCI SOLUTIONS INC. ALL RIGHTS RESERVED.</small>	

TOLERANCES ON DIMENSIONS UNLESS OTHERWISE SPECIFIED			
X* = ±2°	.XX = ±.015	MACHINE FINISH = .125	
X/X = ±1/32	.XXX = ±.010		
PART NO.	SEE TABLE	DRN	DATE
		Frank Basile	07/31/14
		CHK. Frank Basile	DATE
		ENG. Peter Altkorn	DATE
		MFG. Rashm Lubman	DATE
		G.C. Peter Altkorn	DATE
NEXT ASSY	USED ON	SALES.	DATE
	APPLICATION BLOCK		

DFCI SOLUTIONS INC.
425 UNION BOULEVARD.
WEST ISLIP, NEW YORK 11795

PA-3500 STUD
3506-**-241563-Z3CT

SIZE	FSCM NO.	DWG. NO.	REV.
A	72794	C3506-241563	B

SCALE: NTS
WEIGHT:
SHEET 1 OF 2

PART NUMBER	"G"
3506-28-241563-Z3CT	.280
3506-29-241563-Z3CT	.290
3506-30-241563-Z3CT	.300
3506-31-241563-Z3CT	.310
3506-32-241563-Z3CT	.320
3506-33-241563-Z3CT	.330
3506-34-241563-Z3CT	.340
3506-35-241563-Z3CT	.350
3506-36-241563-Z3CT	.360
3506-37-241563-Z3CT	.370
3506-38-241563-Z3CT	.380
3506-39-241563-Z3CT	.390
3506-40-241563-Z3CT	.400
3506-41-241563-Z3CT	.410
3506-42-241563-Z3CT	.420
3506-43-241563-Z3CT	.430
3506-44-241563-Z3CT	.440
3506-45-241563-Z3CT	.450
3506-46-241563-Z3CT	.460
3506-47-241563-Z3CT	.470
3506-48-241563-Z3CT	.480
3506-49-241563-Z3CT	.490
3506-50-241563-Z3CT	.500
3506-51-241563-Z3CT	.510
3506-52-241563-Z3CT	.520
3506-53-241563-Z3CT	.530
3506-54-241563-Z3CT	.540
3506-55-241563-Z3CT	.550
3506-56-241563-Z3CT	.560
3506-57-241563-Z3CT	.570
3506-58-241563-Z3CT	.580
3506-59-241563-Z3CT	.590
3506-60-241563-Z3CT	.600
3506-61-241563-Z3CT	.610
3506-62-241563-Z3CT	.620

REVISIONS			
SYS	DESCRIPTION	DATE	APPROV
B	PER ECN 1168 & 1249	07/31/14	FB

NOTES:

- HEAT TREAT:
A. STEEL STUD HARDNESS = ROCKWELL C30 - 38
B. NO HEAT TREATMENT ON STAINLESS STEEL STUDS
- FINISH:
ZINC PLATE PER ASTM-B-633, TYPE III, SC2, CLEAR TRIVALENT CHROMATE WITH SEALER. (RoHS COMPLIANT) FINISH SUFFIX: Z3CT

THE ABOVE MENTIONED FINSH WILL BE SUPPLIED AS THE STANDARD FINISH UPON DEPLETION OF EXISTING STOCK WHICH ARE FINISHED AS FOLLOWS:
CADMIUM PLATE PER QQ-P-416, TYPE 1, CLASS 2, CLEAR CHROMATE.
- FOR A STUD MADE FROM STAINLESS STEEL, REMOVE THE SUFFIX -Z3CT FROM THE PART NUMBER AND ADD -SS EXAMPLE: 3506-28-241563-SS
- FOR THE APPLICATION OF ALTERNATIVE FINISHES, REMOVE THE SUFFIX -Z3CT FROM THE PART NUMBER AND ADD THE REQUIRED FINISH SUFFIX TO THE PART NUMBER. EXAMPLE FOR YELLOW ZINC TRIVALENT CHROMATE FINISH, THE PART NUMBER WOULD BE 3506-28-241563-Z3YT
- PLEASE VISIT WWW.DFCIS.COM/C3506-241563 FOR A LIST OF AVAILABLE FINISHES.

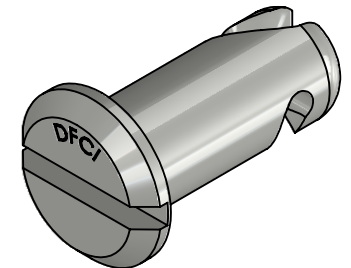

UNCONTROLLED

MATERIAL: A.I.S.I. 8620, 4037 STEEL OR TYPE 303 STAINLESS STEEL		TOLERANCES ON DIMENSIONS UNLESS OTHERWISE SPECIFIED X* = ±2* .XX = ±.015 X/X = ±1/32 .XXX = ±.010 MACHINE FINISH = .125		 DFCI SOLUTIONS INC. 425 UNION BOULEVARD. WEST ISLIP, NEW YORK 11795		
HEAT TREAT: SEE NOTE 1		PART NO. SEE TABLE	DRN Frank Basile DATE 07/31/14			TITLE PA-3500 STUD 3506-**-241563-Z3CT
FINISH: SEE NOTE 2			CHK. Frank Basile DATE	SIZE A FSCM NO 72794 DWG. NO. C3506-241563 REV. B		
THE FASTENER PARTS SHOWN IN THIS PRINT ARE PROPRIETARY ARTICLES TO WHICH DFCI SOLUTIONS INC., RETAINS THE EXCLUSIVE RIGHTS OF MANUFACTURE, USE AND SALE. THE PRINT OR DRAWING IS SUBMITTED IN CONFIDENCE AND DOES NOT CONVEY A LICENSE OR PERMISSION TO MANUFACTURE THE FASTENER OR FASTENER PARTS. (C) COPYRIGHT 2009, DFCI SOLUTIONS INC. ALL RIGHTS RESERVED.			ENG. Frank Basile DATE			SCALE: NTS WEIGHT: SHEET 2 OF 2
			MFG. Radu Iacoban DATE			
		NEXT ASSY	USED ON	G.C. Frank Basile DATE		
		APPLICATION BLOCK		SALES. DATE		