

REVISIONS			
SYS	DESCRIPTION	DATE	APPROV
A	INITIAL RELEASE	04-19-13	

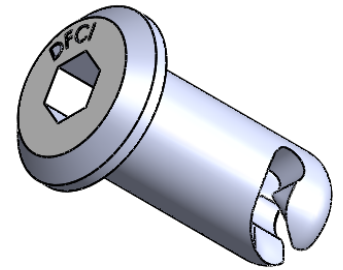
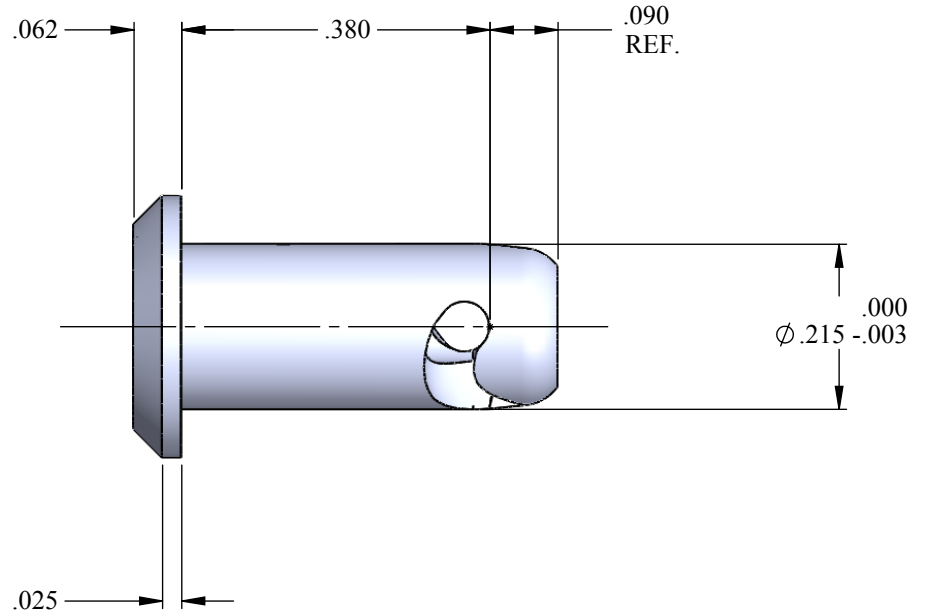
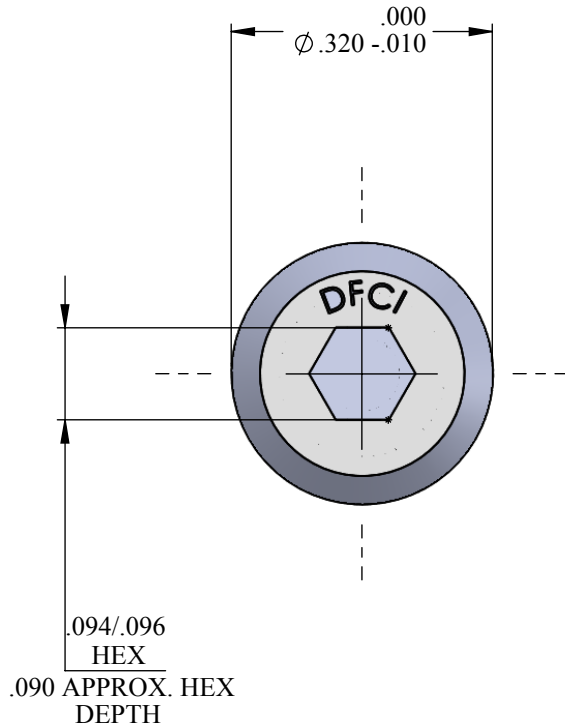

**UNCONTROLLED**

MATERIAL:	A.I.S.I. 8620 OR 4037 STEEL
HEAT TREAT:	ROCKWELL C30 - 38
FINISH:	BLACK OXIDE OVER COPPER PER MIL-C-14550
THE FASTENER PARTS SHOWN IN THIS PRINT ARE PROPRIETARY ARTICLES TO WHICH DFCI SOLUTIONS INC., RETAINS THE EXCLUSIVE RIGHTS OF MANUFACTURE, USE AND SALE. THE PRINT OR DRAWING IS SUBMITTED IN CONFIDENCE AND DOES NOT CONVEY A LICENSE OR PERMISSION TO MANUFACTURE THE FASTENER OR FASTENER PARTS. (C) COPYRIGHT 2009, DFCI SOLUTIONS INC. ALL RIGHTS RESERVED.	

TOLERANCES ON DIMENSIONS UNLESS OTHERWISE SPECIFIED			
X° = ±2°	.XX = ±.015	MACHINE FINISH = 125/7	
X/X = ±1/32	.XXX = ±.010		
PART NO.	3506-38-241896-BOC	DRN	DATE
		Frank Basile	04-19-13
		CHK. Frank Basile	DATE 04-19-13
		ENG. Peter Altkorn	DATE 04-19-13
		MFG. Rashm Lubman	DATE 04-19-13
		G.C. Peter Altkorn	DATE 04-19-13
NEXT ASSY	USED ON	SALES.	DATE

		<b>DFCI SOLUTIONS INC.</b> 425 UNION BOULEVARD. WEST ISLIP, NEW YORK 11795	
TITLE PA-3500 HEX RECESS STUD 3506-38-241896-BOC			
SIZE	FSCM NO.	DWG. NO.	REV.
A	72794	C3506-241896	A
SCALE: NTS		WEIGHT:	SHEET 1 OF 1