

UNCONTROLLED

C3519 REV. C

REVISIONS			
SYM	DESCRIPTION	DATE	APPROV
C	CHNG P/N PER ECN 989	9-26-06	R. OLSON

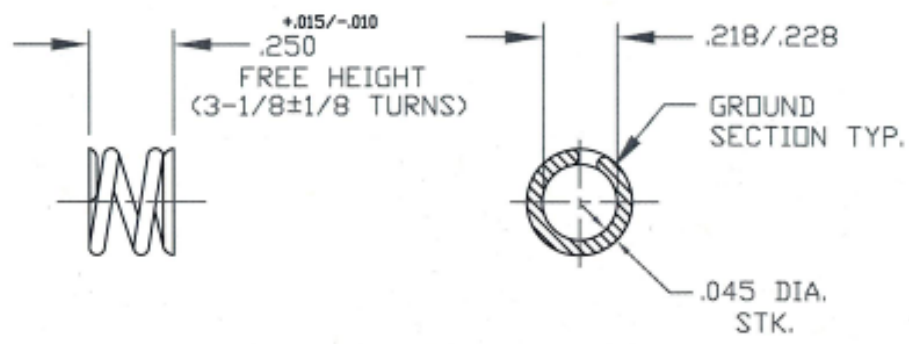

NOTES:

- FINISH:
ZINC PLATE PER ASTM-B-633, TYPE III, SC 2, CLEAR TRIVALENT CHROMATE WITH SEALER. (RoHS COMPLIANT) FINISH SUFFIX: -Z3CT
THE ABOVE MENTIONED FINISH WILL BE SUPPLIED AS THE STANDARD FINISH, UPON DEPLETION OF EXISTING STOCK WHICH ARE FINISHED AS FOLLO: CADMIUM PLATE PER QQ-P-416, TYPE I, CLASS 2, CLEAR CHROMATE. (FINISH SUFFIX: -C3C)
- FOR THE APPLICATION OF ALTERNATIVE FINISHES, REMOVE SUFFIX -Z3CT FROM THE PART NO. AND ADD THE REQUIRED FINISH TO THE PART NO. SUFFIX. *EXAMPLE FOR BLACK ZINC TRIVALENT CHROMATE FINISH, THE PART NO. IS 3519-Z3BT.

PART NO.	MATERIAL	FINISH
3519-Z3CT	MUSIC WIRE PER ASTM-A-228.	PER NOTE 1.
3519-SS	STAINLESS STEEL TYPE 316.	NONE.

MAT'L AS NOTED.		TOLERANCES ON DIMENSIONS UNLESS OTHERWISE SPECIFIED X* = ±.2* .XX = ±.015 X/X = ±1/32 .XXX = ±.010		MACHINE FINISH 125T		DFCI SOLUTIONS INC. 425 UNION BOULEVARD WEST ISLIP, NEW YORK 11795	
HEAT TREAT NONE.		PART NO.	DRN S. FRANGS	DATE 9-30-03	TITLE 3500 SPRING, PANEL LINE, 3519-Z3CT.		
FINISH PER NOTE 1.			CHK F. Basil	DATE 10-5-06	SIZE A		
THE PARTS SHOWN IN THIS PRINT ARE PROPRIETARY ARTICLES TO WHICH DFCI SOLUTIONS INC. RETAINS THE EXCLUSIVE RIGHTS OF MANUFACTURE, USE AND SALE. THE PRINT OR DRAWING IS SUBMITTED IN CONFIDENCE AND DOES NOT CONVEY A LICENSE OR PERMISSION TO MANUFACTURE THE PARTS OR PARTS THEREOF.			ENG R. OLSON	DATE 10/5/06	FSCM NO 72794	DWG. NO. C3519	REV. C
DATE: 07/01/06 FORM: DRAWING		NEXT ASSY	USED ON	QC B. Nelson	DATE 10/16/06	SCALE NTS	WT.
APPLICATION BLOCK		SALES	DATE	SHEET 1 OF 1			