

UNCONTROLLED

C3590-241248 SHT. 1 of 2 REV. D

REVISIONS			
SYM	DESCRIPTION	DATE	APPROV
D	CHNG P/N, ADD WEIGHT ECN 1117	11-24-08	<i>FB</i>

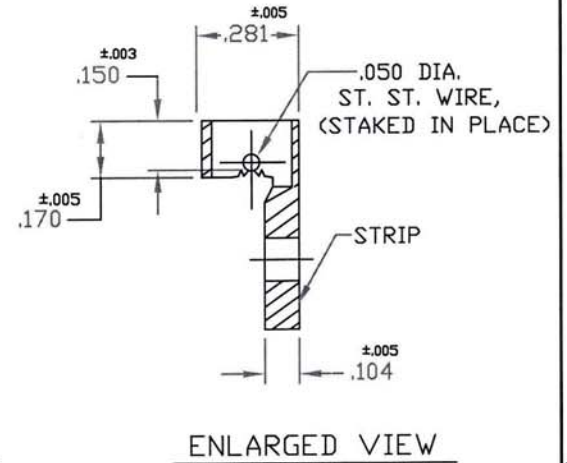
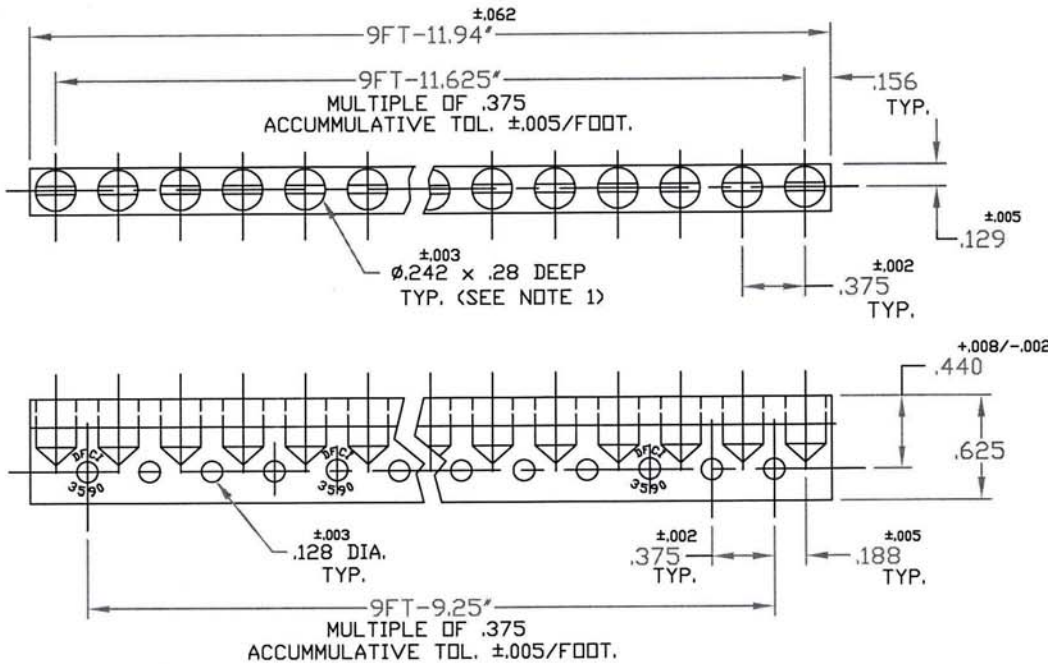

FOR PART NO. REFER TO SHT. 2 of 2.

MAT'L <b>AS NOTED.</b>	TOLERANCES ON DIMENSIONS UNLESS OTHERWISE SPECIFIED X = ±2° .XX = ±.015 X/X = ±1/32 .XXX = ±.010 MACHINE FINISH 125/T			<b>DFCI SOLUTIONS INC.</b> 425 UNION BOULEVARD WEST ISLIP, NEW YORK 11795		
	HEAT TREAT TEMPERED AS NOTED.	PART NO.	DRN <i>S. FRANCIS</i> DATE 2-11-05			
FINISH <b>AS NOTED.</b>		CHK <i>F. Basil</i> DATE 11-24-08	<b>PA-3500 LINE RECEPTACLE,</b> <b>3590-241248.</b>			
		ENG <i>B. Hildebrand</i> DATE 11/24/08				
<small>THE FASTENER PARTS SHOWN IN THIS PRINT ARE PROPRIETARY ARTICLES TO WHICH DFCI SOLUTIONS INC. RETAINS THE EXCLUSIVE RIGHTS OF MANUFACTURE, USE AND SALE. THE PRINT OR DRAWING IS SUBMITTED IN CONFIDENCE AND DOES NOT CONVEY A LICENSE OR PERMISSION TO MANUFACTURE THE FASTENER OR FASTENER PARTS.</small> <small>© COPYRIGHT 2003, DFCI SOLUTIONS INC. ALL RIGHTS RESERVED.</small>	NEXT ASSY	MFB <i>[Signature]</i> DATE 11/24/08	SIZE <b>A</b>	FSCM NO <b>72794</b>	DWG. NO. <b>C3590-241248</b>	REV. <b>D</b>
	APPLICATION BLOCK	USED ON SALES	DATE	SCALE NTS	WT.	SHEET 1 OF 2

DATE: 07/01/06 FORM: DRAWING

The parts shown in this print are proprietary articles to which DFCI Solutions, Inc. retains the exclusive rights of manufacture, use and sale. The print or drawing is submitted in confidence and does not convey a license or permission to manufacture the parts. Copyright © 2008 by DFCI Solutions, Inc. All rights reserved.

UNCONTROLLED

REVISIONS			
SYM	DESCRIPTION	DATE	APPROV
D	CHNG P/N, ADD WEIGHT ECN 1117	11-24-08	<i>FB</i>

PART NO.	STAMP W/DFCI P/N ONCE PER STRIP	NUMBER OF Ø.242 HOLES PER STRIP	WEIGHT (LBS.)	MATERIAL			FINISH
				STRIP	TEMPER (STRIP)	WIRE	
3590-241248	3590-241248	320	.836	6061-T6511 ALUM.	T6511 SEE NOTE 2	STAINLESS STEEL, SPRING TEMPER, TYPE 316, PER ASTM-A-313	CHROMATE ALUM. COATING PER MIL-C-5541, CLASS 3. AND PER MIL-C-81706, CLASS 3.
3590-241248A	3590-241248A			7075-T73511 ALUM.	T73511 SEE NOTE 2		
3590-241248B	3590-241248B			6061-T6 ALUM.	T6		

NOTES:

- SOME DISTORTION MAY ENTER THE .242 DIA. HOLE, DUE TO STAKING OF WIRE. THIS WILL NOT AFFECT THE FUNCTION OF THE PRODUCT.
- SPECIAL TEMPERING PROCESS (T-511) FOR THE STRIP.

MAT'L <b>AS NOTED.</b>	TOLERANCES ON DIMENSIONS UNLESS OTHERWISE SPECIFIED X* = ±2° .XX = ±.015 X/X = ±1/32 .XXX = ±.010		MACHINE FINISH <u>125T</u>			DFCI SOLUTIONS INC. 425 UNION BOULEVARD WEST ISLIP, NEW YORK 11795			
HEAT TREAT TEMPERED AS NOTED.	PART NO.	DRN <i>S. Francis</i>	DATE 2-11-05	CHK <i>F. Brazil</i>		TYPE <b>PA-3500 LINE RECEPTACLE,</b> <b>3590-241248.</b>			
FINISH <b>AS NOTED.</b>		ENG <i>B. Dilabel</i>	DATE 11-24-08	MFG <i>B. Dilabel</i>	DATE 11/24/08	SIZE <b>A</b>	FSCM NO <b>72794</b>	DWG. NO. <b>C3590-241248</b>	REV. <b>D</b>
<small>THE FASTENER PARTS SHOWN IN THIS PRINT ARE PROPRIETARY ARTICLES TO WHICH DFCI SOLUTIONS INC. RETAINS THE EXCLUSIVE RIGHTS OF MANUFACTURE, USE AND SALE. THE PRINT OR DRAWING IS SUBMITTED IN CONFIDENCE AND DOES NOT CONVEY A LICENSE OR PERMISSION TO MANUFACTURE THE FASTENER OR FASTENER PARTS.</small>	NEXT ASSY	USED ON	SALES	DATE	SCALE NTS	WT.	SHEET <b>2 OF 2</b>		

DATE: 07/01/06 FORM: DRAWING