

UNCONTROLLED

C3590-241250 SHT. 1 of 2 REV. C

REVISIONS			
SYM	DESCRIPTION	DATE	APPROV
C	ADD SHT. 2 PER ECN 1089	7-22-08	R.E.

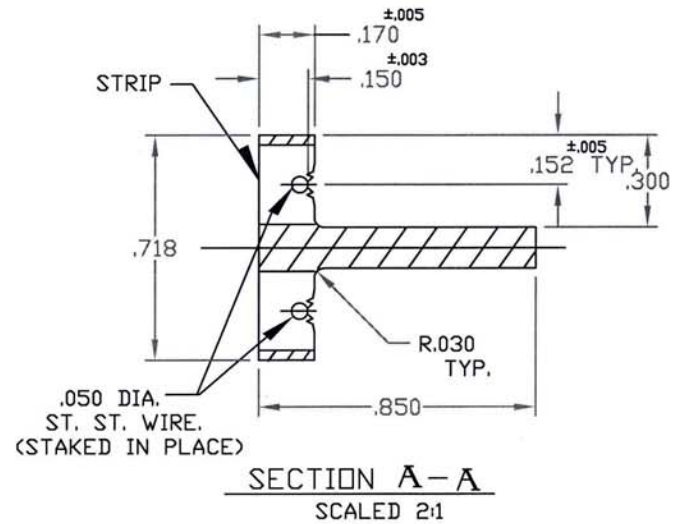
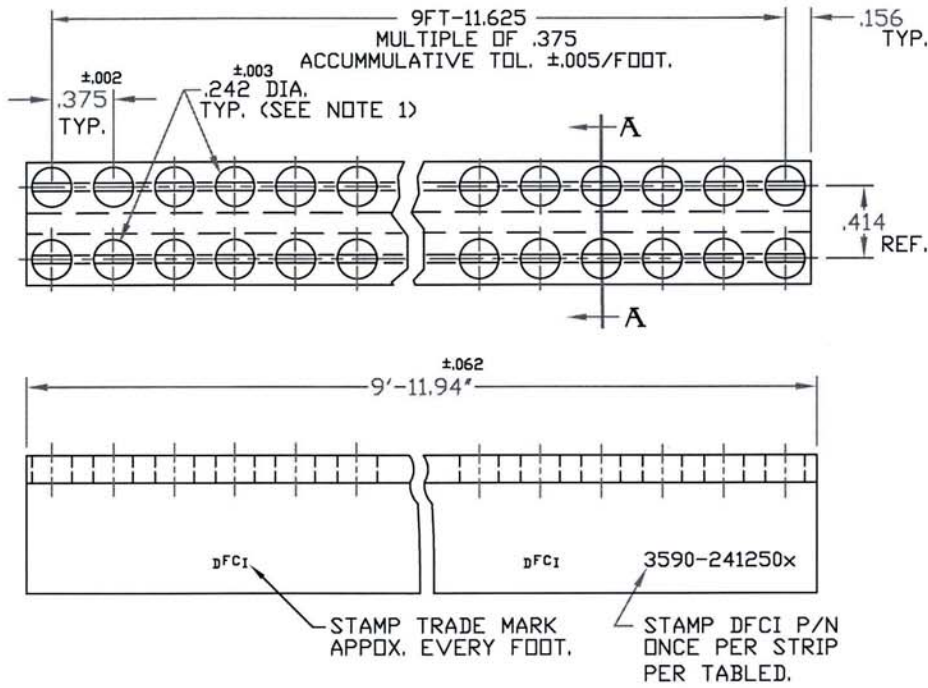

FOR PART NO. REFER TO SHT. 2 of 2.

MAT'L AS NOTED.	TOLERANCES ON DIMENSIONS UNLESS OTHERWISE SPECIFIED X = ±2" .XX = ±.015 X/X = ±1/32 .XXX = ±.010 MACHINE FINISH 125		DFCI SOLUTIONS INC. 425 UNION BOULEVARD WEST ISLIP, NEW YORK 11795	
HEAT TREAT TEMPERED AS NOTED.	PART NO.	DRN S. Francis DATE 2-11-05	PA-3500 LINE RECEPTACLE, 3590-241250.	
FINISH AS NOTED.		CHK F. Basile DATE 7-30-08		
<small>THE FASTENER PARTS SHOWN IN THIS PRINT ARE PROPRIETARY ARTICLES TO WHICH DFCI SOLUTIONS INC. RETAINS THE EXCLUSIVE RIGHTS OF MANUFACTURE, USE AND SALE. THE PRINT OR DRAWING IS SUBMITTED IN CONFIDENCE AND DOES NOT CONVEY A LICENSE OR PERMISSION TO MANUFACTURE THE FASTENER OR FASTENER PARTS.</small> <small>© COPYRIGHT 2003, DFCI SOLUTIONS INC. ALL RIGHTS RESERVED.</small> DATE: 07/01/06 FORM: DRAWING	NEXT ASSY	USED ON	ENG Cochran DATE 7-28-08 MFG Bill Hill DATE 7-28-08	SIZE A FSCM NO 72794 DWG. NO. C3590-241250 REV. C
	APPLICATION BLOCK	SALES	DATE	SCALE NTS WT. SHEET 1 OF 2

UNCONTROLLED

REVISIONS			
SYM	DESCRIPTION	DATE	APPROV
C	ADD SHT. 2 PER ECN 1089	7-22-08	R.c.

PART NO.	STAMP W/DFCI P/N ONCE PER STRIP	NUMBER OF Ø.242 HOLES PER STRIP	MATERIAL			FINISH
			STRIP	TEMPER (STRIP)	WIRE	
3590-241250	3590-241250	320 PER ROW	6061-T6511 ALUM.	T6511 SEE NOTE 2	STAINLESS STEEL, SPRING TEMPER, TYPE 316, PER ASTM-A-313	CHROMATE ALUM. COATING PER MIL-C-5541, CLASS 3. AND PER MIL-C-81706, CLASS 3.
3590-241250A	3590-241250A		7075-T73511 ALUM.	T73511 SEE NOTE 2		
3590-241250B	3590-241250B		6061-T6 ALUM.	T6		

NOTES:

- SOME DISTORTION MAY ENTER THE .242 DIA. HOLE, DUE TO STAKING OF WIRE. THIS WILL NOT AFFECT THE FUNCTION OF THE PRODUCT.
- SPECIAL TEMPERING PROCESS (T-511) FOR THE STRIP.

MAT'L AS NOTED.	TOLERANCES ON DIMENSIONS UNLESS OTHERWISE SPECIFIED X* = ±2* .XX = ±.015 X/X = ±1/32 .XXX = ±.010		MACHINE FINISH 125T		 DFCI SOLUTIONS INC. 425 UNION BOULEVARD WEST ISLIP, NEW YORK 11795			
HEAT TREAT TEMPERED AS NOTED.	PART NO.	DRN S. FRANKS	DATE 2-11-05	PA-3500 LINE RECEPTACLE, 3590-241250.				
FINISH AS NOTED.		CHK F. Basil	DATE 7-30-08					
		ENG Cedric Coeborn	DATE 7-28-08					
<small>THE FASTENER PARTS SHOWN IN THIS PRINT ARE PROPRIETARY ARTICLES TO WHICH DFCI SOLUTIONS INC. RETAINS THE EXCLUSIVE RIGHTS OF MANUFACTURE, USE AND SALE. THE PRINT OR DRAWING IS SUBMITTED IN CONFIDENCE AND DOES NOT CONVEY A LICENSE OR PERMISSION TO MANUFACTURE THE FASTENER OR FASTENER PARTS.</small>	NEXT ASSY	USED ON	MFG Bill Hill	DATE 7-28-08	SIZE A	FSCM NO 72794	DWG. NO. C3590-241250	REV. C
<small>© COPYRIGHT 2003, DFCI SOLUTIONS INC. ALL RIGHTS RESERVED.</small>	APPLICATION BLOCK		SALES B. Hill	DATE 7-28-08	SCALE NTS	WT.	SHEET 2 OF 2	