

UNCONTROLLED

C3590-241856 REV. A

REVISIONS			
SYM	DESCRIPTION	DATE	APPROV
A	INITIAL RELEASE PER ECN 845.	6-23-09	<i>FJB</i>

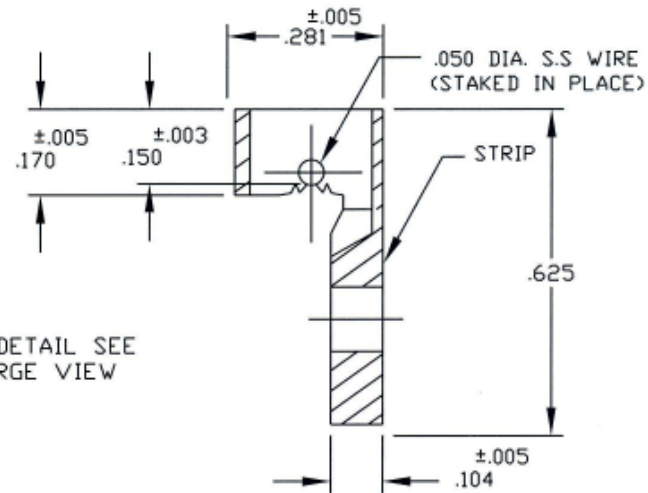
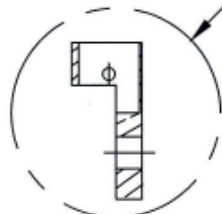
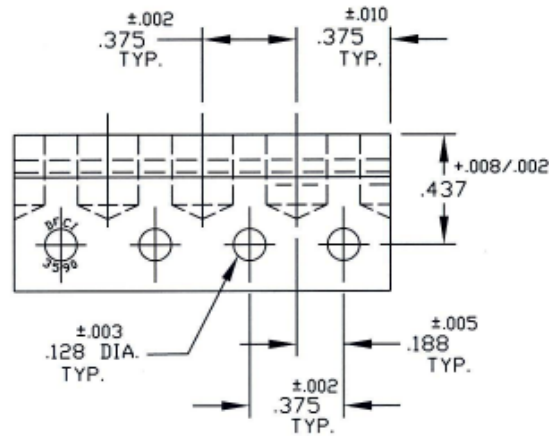
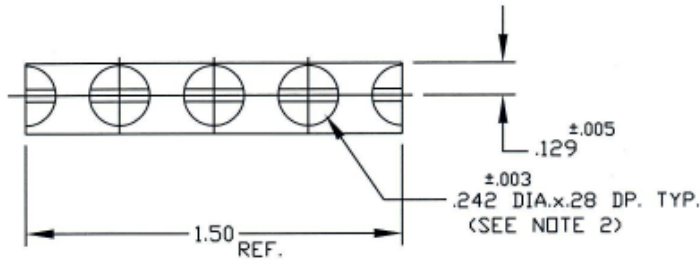

FOR DETAIL SEE ENLARGE VIEW

ENLARGED VIEW  
STAKING OF WIRE

NOTES:

- MATERIALS:  
STRIP: 6061-T6 ALUM. ALLOY PER QQ-A-200/8.  
WIRE: .050 DIA. ST. STEEL TYPE 316, PER ASTM-A-313, SPRING TEMPER.
- SOME DISTORTION MAY ENTER THE .242 DIA. HOLE, DUE TO STAKING OF WIRE. THIS WILL NOT AFFECT THE FUNCTION OF THE PRODUCT.
- PLEASE VISIT [WWW.DFCIS.COM/C3590-241856](http://WWW.DFCIS.COM/C3590-241856) FOR A LIST OF AVAILABLE FINISHES.

PART NO.	NUMBER OF Ø.242 HOLE	WEIGHT
3590-241856-H3	3	.0100 LBS.

MAT'L PER NOTE 1.	TOLERANCES ON DIMENSIONS UNLESS OTHERWISE SPECIFIED X = ±2* .XX = ±.015 X/X = ±1/32 .XXX = ±.010 MACHINE FINISH .125	
HEAT TREAT PER NOTE I.	PART NO.	DRN S. FRANDIS DATE 6-23-09
FINISH NATURAL.		CHK F. BOBIS DATE 6-24-09
		ENG B. HILDELY DATE 6/24/09
		MFG B. HILDELY DATE 6/24/09
		QC B. HILDELY DATE 6/24/09
	NEXT ASSY	USED ON
	SALES	DATE

DFCI SOLUTIONS INC. 425 UNION BOULEVARD WEST ISLIP, NEW YORK 11795		REV. A
TITLE PA-3500 CUT RECEPTACLE, 3590-241856-H3.		
SIZE A	FSCM NO 72794	DWG. NO. C3590-241856
SCALE NTS	WT.	SHEET 1 OF 1

DATE: 07/01/06 FORM: DRAWING