

PART NUMBER	NUMBER OF ϕ.242 HOLES PER STRIP
3590-241885-H100-AC1Y	100

REVISIONS			
SYS	DESCRIPTION	DATE	APPROV
B	PER ECN 1214	10-03-12	

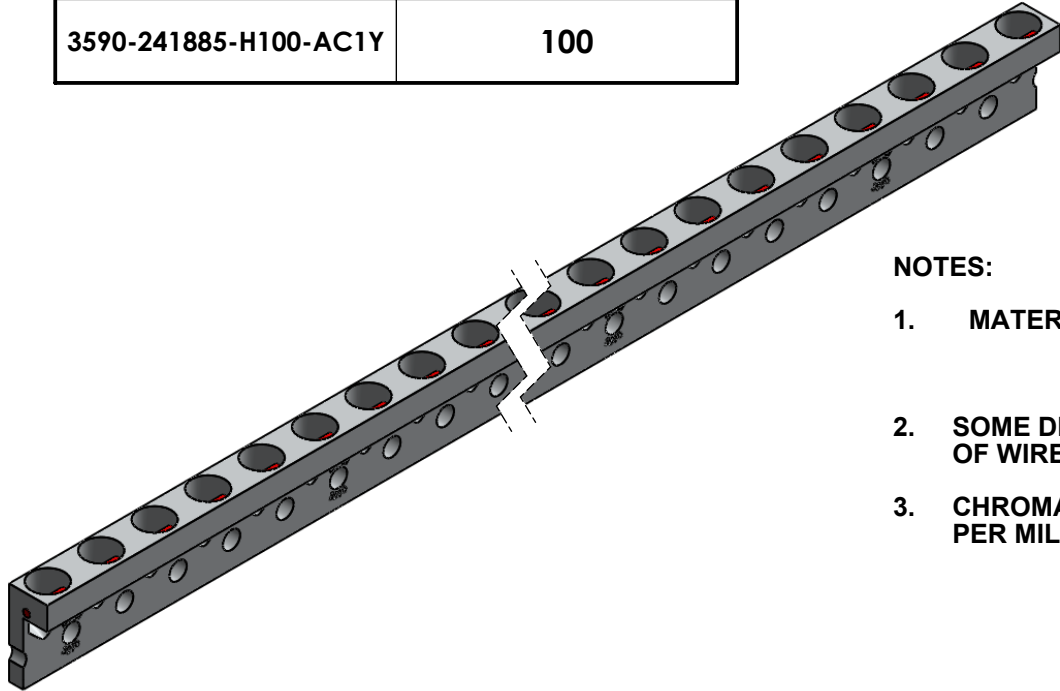

NOTES:

- 1. MATERIALS: STRIP- 6061-T6 ALUMINUM ALLOY PER QQ-A-200/8
WIRE- ϕ .050 STAINLESS STEEL TYPE 316 PER ASTM-A-313
SPRING TEMPER.**
- 2. SOME DISTORTION MAY ENTER THE ϕ .242 HOLE DUE TO STAKING
OF WIRE. THIS WILL NOT AFFECT THE FUNCTION OF THE PRODUCT.**
- 3. CHROMATE ALUMINUM CONVERSION COATING, YELLOW IN COLOR
PER MIL-DTL-C-5541, TYPE I, CLASS 1A & MIL-C-81706, CLASS 3**

UNCONTROLLED

MATERIAL: SEE NOTE 1
HEAT TREAT: TEMPER COND. T6
FINISH: SEE NOTE 3
THE FASTENER PARTS SHOWN IN THIS PRINT ARE PROPRIETARY ARTICLES TO WHICH DFCI SOLUTIONS INC., RETAINS THE EXCLUSIVE RIGHTS OF MANUFACTURE, USE AND SALE. THE PRINT OR DRAWING IS SUBMITTED IN CONFIDENCE AND DOES NOT CONVEY A LICENSE OR PERMISSION TO MANUFACTURE THE FASTENER OR FASTENER PARTS.
(C) COPYRIGHT 2009, DFCI SOLUTIONS INC. ALL RIGHTS RESERVED.

TOLERANCES ON DIMENSIONS UNLESS OTHERWISE SPECIFIED			
X° = $\pm 2^\circ$.XX = ± 0.015	MACHINE FINISH = .125	
X/X = $\pm 1/32$.XXX = ± 0.010		
PART NO.	DRN	DATE	
	<i>Frank Basile</i>	06-01-12	
	CHK. <i>Frank Basile</i>	06-01-12	
	ENG. <i>Robert Altkorn</i>	06-01-12	
	MFG. <i>Rashm Lubman</i>	06-01-12	
	Q.C. <i>Robert Altkorn</i>	06-01-12	
NEXT ASSY	USED ON	SALES.	DATE
APPLICATION BLOCK			

DFCI SOLUTIONS INC.
425 UNION BOULEVARD.
WEST ISLIP, NEW YORK 11795

TITLE		3590-241885-H100-AC1Y PA-3500 RECEPTACLE STRIP	
SIZE	FSCM NO.	DWG. NO.	REV.
A	72794	C3590-241885	B
SCALE: NTS		WEIGHT:	SHEET 2 OF 2