

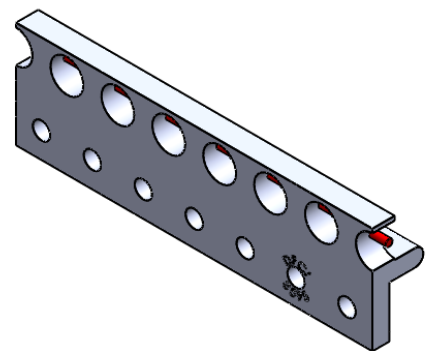

REVISIONS			
SYS	DESCRIPTION	DATE	APPROV
A	INITIAL RELEASE	04-10-13	

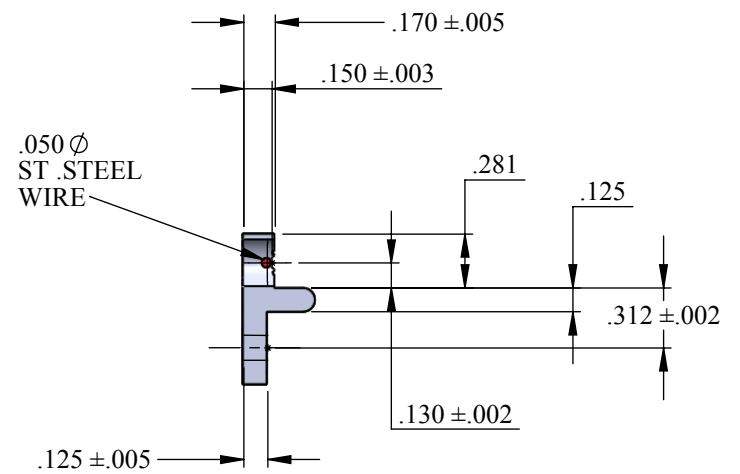
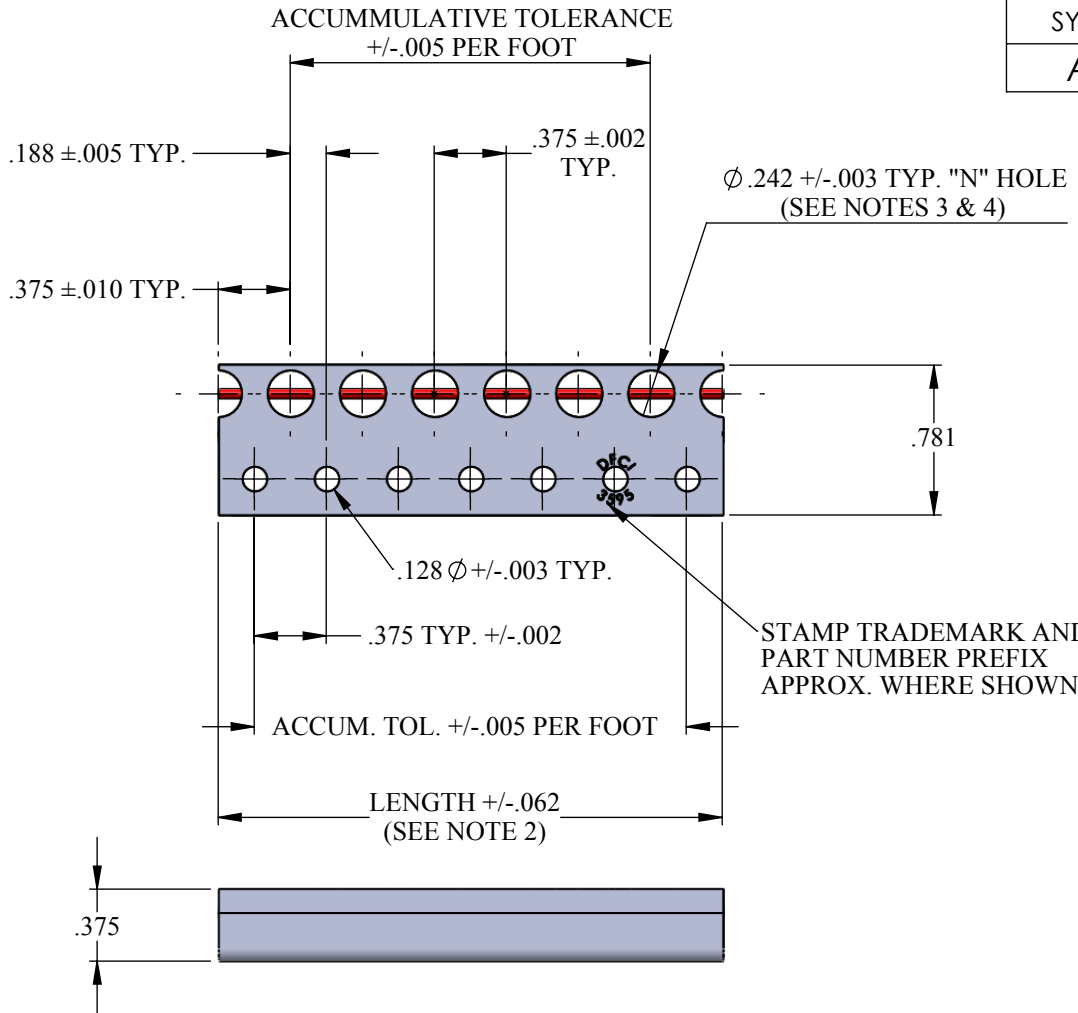

UNCONTROLLED

MATERIAL: SEE NOTE 1	TOLERANCES ON DIMENSIONS UNLESS OTHERWISE SPECIFIED				 DFCI SOLUTIONS INC. 425 UNION BOULEVARD. WEST ISLIP, NEW YORK 11795	
HEAT TREAT: TEMPER COND. T6	X* = ±2° X/X = ±1/32 .XX = ±.015 .XXX = ±.010 MACHINE FINISH = 1257	PART NO. SEE TABLES	DRN <i>Frank Basile</i>	DATE 04-10-13		
FINISH: NONE			CHK. <i>Frank Basile</i>	DATE 04-10-13	TITLE PA-3500 RECEPTACLE STRIP 3595-241895-H***	
THE FASTENER PARTS SHOWN IN THIS PRINT ARE PROPRIETARY ARTICLES TO WHICH DFCI SOLUTIONS INC., RETAINS THE EXCLUSIVE RIGHTS OF MANUFACTURE, USE AND SALE. THE PRINT OR DRAWING IS SUBMITTED IN CONFIDENCE AND DOES NOT CONVEY A LICENSE OR PERMISSION TO MANUFACTURE THE FASTENER OR FASTENER PARTS. (C) COPYRIGHT 2009, DFCI SOLUTIONS INC. ALL RIGHTS RESERVED.			ENG. <i>Robert Aldebrand</i>	DATE 04-10-13		
			MFG. <i>Rashid Zubair</i>	DATE 04-10-13		
			G.C. <i>Robert Aldebrand</i>	DATE 04-10-13	SIZE A FSCM NO. 72794 DWG. NO. C3595-241895-H REV. A	
			SALES.	DATE	SCALE: NTS WEIGHT: SHEET 1 OF 5	

UNCONTROLLED

REVISIONS			
SYS	DESCRIPTION	DATE	APPROV
A	INITIAL RELEASE	04-10-13	

PART NUMBER	NUMBER OF HOLES
3595-241895-H1	1
3595-241895-H2	2
3595-241895-H3	3
3595-241895-H4	4
3595-241895-H5	5
3595-241895-H6	6
3595-241895-H7	7
3595-241895-H8	8
3595-241895-H9	9
3595-241895-H10	10
3595-241895-H11	11
3595-241895-H12	12
3595-241895-H13	13
3595-241895-H14	14
3595-241895-H15	15
3595-241895-H16	16
3595-241895-H17	17
3595-241895-H18	18
3595-241895-H19	19
3595-241895-H20	20
3595-241895-H21	21
3595-241895-H22	22
3595-241895-H23	23
3595-241895-H24	24
3595-241895-H25	25

PART NUMBER	NUMBER OF HOLES
3595-241895-H26	26
3595-241895-H27	27
3595-241895-H28	28
3595-241895-H29	29
3595-241895-H30	30
3595-241895-H31	31
3595-241895-H32	32
3595-241895-H33	33
3595-241895-H34	34
3595-241895-H35	35
3595-241895-H36	36
3595-241895-H37	37
3595-241895-H38	38
3595-241895-H39	39
3595-241895-H40	40
3595-241895-H41	41
3595-241895-H42	42
3595-241895-H43	43
3595-241895-H44	44
3595-241895-H45	45
3595-241895-H46	46
3595-241895-H47	47
3595-241895-H48	48
3595-241895-H49	49
3595-241895-H50	50

PART NUMBER	NUMBER OF HOLES
3595-241895-H51	51
3595-241895-H52	52
3595-241895-H53	53
3595-241895-H54	54
3595-241895-H55	55
3595-241895-H56	56
3595-241895-H57	57
3595-241895-H58	58
3595-241895-H59	59
3595-241895-H60	60
3595-241895-H61	61
3595-241895-H62	62
3595-241895-H63	63
3595-241895-H64	64
3595-241895-H65	65
3595-241895-H66	66
3595-241895-H67	67
3595-241895-H68	68
3595-241895-H69	69
3595-241895-H70	70
3595-241895-H71	71
3595-241895-H72	72
3595-241895-H73	73
3595-241895-H74	74
3595-241895-H75	75

PART NUMBER	NUMBER OF HOLES
3595-241895-H76	76
3595-241895-H77	77
3595-241895-H78	78
3595-241895-H79	79
3595-241895-H80	80
3595-241895-H81	81
3595-241895-H82	82
3595-241895-H83	83
3595-241895-H84	84
3595-241895-H85	85
3595-241895-H86	86
3595-241895-H87	87
3595-241895-H88	88
3595-241895-H89	89
3595-241895-H90	90
3595-241895-H91	91
3595-241895-H92	92
3595-241895-H93	93
3595-241895-H94	94
3595-241895-H95	95
3595-241895-H96	96
3595-241895-H97	97
3595-241895-H98	98
3595-241895-H99	99
3595-241895-H100	100

MATERIAL: SEE NOTE 1

HEAT TREAT: TEMPER COND. T6

FINISH: NONE

THE FASTENER PARTS SHOWN IN THIS PRINT ARE PROPRIETARY ARTICLES TO WHICH DFCI SOLUTIONS INC., RETAINS THE EXCLUSIVE RIGHTS OF MANUFACTURE, USE AND SALE. THE PRINT OR DRAWING IS SUBMITTED IN CONFIDENCE AND DOES NOT CONVEY A LICENSE OR PERMISSION TO MANUFACTURE THE FASTENER OR FASTENER PARTS.

(C) COPYRIGHT 2009, DFCI SOLUTIONS INC. ALL RIGHTS RESERVED.

TOLERANCES ON DIMENSIONS UNLESS OTHERWISE SPECIFIED

X* = ±2° .XX = ±.015
X/X = ±1/32 .XXX = ±.010

MACHINE FINISH = .125

PART NO.	SEE TABLES	DRN	Frank Basile	DATE	04-10-13
		CHK.	Frank Basile	DATE	04-10-13
		ENG.	Robert Altkorn	DATE	04-10-13
		MFG.	Rashid Lubman	DATE	04-10-13
		G.C.	Robert Altkorn	DATE	04-10-13
NEXT ASSY	USED ON	SALES		DATE	

APPLICATION BLOCK



DFCI SOLUTIONS INC.
425 UNION BOULEVARD.
WEST ISLIP, NEW YORK 11795

TITLE: PA-3500 RECEPTACLE STRIP
3595-241895-H***

SIZE	FSCM NO.	DWG. NO.	REV.
A	72794	C3595-241895-H	A

SCALE: NTS WEIGHT: SHEET 2 OF 5

UNCONTROLLED

REVISIONS			
SYS	DESCRIPTION	DATE	APPROV
A	INITIAL RELEASE	04-10-13	

PART NUMBER	NUMBER OF HOLES
3595-241895-H101	101
3595-241895-H102	102
3595-241895-H103	103
3595-241895-H104	104
3595-241895-H105	105
3595-241895-H106	106
3595-241895-H107	107
3595-241895-H108	108
3595-241895-H109	109
3595-241895-H110	110
3595-241895-H111	111
3595-241895-H112	112
3595-241895-H113	113
3595-241895-H114	114
3595-241895-H115	115
3595-241895-H116	116
3595-241895-H117	117
3595-241895-H118	118
3595-241895-H119	119
3595-241895-H120	120
3595-241895-H121	121
3595-241895-H122	122
3595-241895-H123	123
3595-241895-H124	124
3595-241895-H125	125

PART NUMBER	NUMBER OF HOLES
3595-241895-H126	126
3595-241895-H127	127
3595-241895-H128	128
3595-241895-H129	129
3595-241895-H130	130
3595-241895-H131	131
3595-241895-H132	132
3595-241895-H133	133
3595-241895-H134	134
3595-241895-H135	135
3595-241895-H136	136
3595-241895-H137	137
3595-241895-H138	138
3595-241895-H139	139
3595-241895-H140	140
3595-241895-H141	141
3595-241895-H142	142
3595-241895-H143	143
3595-241895-H144	144
3595-241895-H145	145
3595-241895-H146	146
3595-241895-H147	147
3595-241895-H148	148
3595-241895-H149	149
3595-241895-H150	150

PART NUMBER	NUMBER OF HOLES
3595-241895-H151	151
3595-241895-H152	152
3595-241895-H153	153
3595-241895-H154	154
3595-241895-H155	155
3595-241895-H156	156
3595-241895-H157	157
3595-241895-H158	158
3595-241895-H159	159
3595-241895-H160	160
3595-241895-H161	161
3595-241895-H162	162
3595-241895-H163	163
3595-241895-H164	164
3595-241895-H165	165
3595-241895-H166	166
3595-241895-H167	167
3595-241895-H168	168
3595-241895-H169	169
3595-241895-H170	170
3595-241895-H171	171
3595-241895-H172	172
3595-241895-H173	173
3595-241895-H174	174
3595-241895-H175	175

PART NUMBER	NUMBER OF HOLES
3595-241895-H176	176
3595-241895-H177	177
3595-241895-H178	178
3595-241895-H179	179
3595-241895-H180	180
3595-241895-H181	181
3595-241895-H182	182
3595-241895-H183	183
3595-241895-H184	184
3595-241895-H185	185
3595-241895-H186	186
3595-241895-H187	187
3595-241895-H188	188
3595-241895-H189	189
3595-241895-H190	190
3595-241895-H191	191
3595-241895-H192	192
3595-241895-H193	193
3595-241895-H194	194
3595-241895-H195	195
3595-241895-H196	196
3595-241895-H197	197
3595-241895-H198	198
3595-241895-H199	199
3595-241895-H200	200

MATERIAL:	SEE NOTE 1
HEAT TREAT:	TEMPER COND. T6
FINISH:	NONE
<small>THE FASTENER PARTS SHOWN IN THIS PRINT ARE PROPRIETARY ARTICLES TO WHICH DFCI SOLUTIONS INC., RETAINS THE EXCLUSIVE RIGHTS OF MANUFACTURE, USE AND SALE. THE PRINT OR DRAWING IS SUBMITTED IN CONFIDENCE AND DOES NOT CONVEY A LICENSE OR PERMISSION TO MANUFACTURE THE FASTENER OR FASTENER PARTS.</small>	
<small>(C) COPYRIGHT 2009, DFCI SOLUTIONS INC. ALL RIGHTS RESERVED.</small>	

TOLERANCES ON DIMENSIONS UNLESS OTHERWISE SPECIFIED			
X* = ±2*		.XX = ±.015	
X/X = ±1/32		.XXX = ±.010	
MACHINE FINISH = .125			
PART NO.	SEE TABLES	DRN	DATE
		Frank Basile	04-10-13
		CHK. Frank Basile	04-10-13
		ENG. Robert Alldred	04-10-13
		MFG. Radu Iubaru	04-10-13
		G.C. Robert Alldred	04-10-13
NEXT ASSY	USED ON	SALES.	DATE
APPLICATION BLOCK			



DFCI SOLUTIONS INC.
425 UNION BOULEVARD.
WEST ISLIP, NEW YORK 11795

PA-3500 RECEPTACLE STRIP
3595-241895-H***

SIZE	FSCM NO	DWG. NO.	REV.
A	72794	C3595-241895-H	A

SCALE: NTS WEIGHT: SHEET 3 OF 5

UNCONTROLLED

REVISIONS			
SYS	DESCRIPTION	DATE	APPROV
A	INITIAL RELEASE	04-10-13	

PART NUMBER	NUMBER OF HOLES
3595-241895-H201	201
3595-241895-H202	202
3595-241895-H203	203
3595-241895-H204	204
3595-241895-H205	205
3595-241895-H206	206
3595-241895-H207	207
3595-241895-H208	208
3595-241895-H209	209
3595-241895-H210	210
3595-241895-H211	211
3595-241895-H212	212
3595-241895-H213	213
3595-241895-H214	214
3595-241895-H215	215
3595-241895-H216	216
3595-241895-H217	217
3595-241895-H218	218
3595-241895-H219	219
3595-241895-H220	220
3595-241895-H221	221
3595-241895-H222	222
3595-241895-H223	223
3595-241895-H224	224
3595-241895-H225	225

PART NUMBER	NUMBER OF HOLES
3595-241895-H226	226
3595-241895-H227	227
3595-241895-H228	228
3595-241895-H229	229
3595-241895-H230	230
3595-241895-H231	231
3595-241895-H232	232
3595-241895-H233	233
3595-241895-H234	234
3595-241895-H235	235
3595-241895-H236	236
3595-241895-H237	237
3595-241895-H238	238
3595-241895-H239	239
3595-241895-H240	240
3595-241895-H241	241
3595-241895-H242	242
3595-241895-H243	243
3595-241895-H244	244
3595-241895-H245	245
3595-241895-H246	246
3595-241895-H247	247
3595-241895-H248	248
3595-241895-H249	249
3595-241895-H250	250

PART NUMBER	NUMBER OF HOLES
3595-241895-H251	251
3595-241895-H252	252
3595-241895-H253	253
3595-241895-H254	254
3595-241895-H255	255
3595-241895-H256	256
3595-241895-H257	257
3595-241895-H258	258
3595-241895-H259	259
3595-241895-H260	260
3595-241895-H261	261
3595-241895-H262	262
3595-241895-H263	263
3595-241895-H264	264
3595-241895-H265	265
3595-241895-H266	266
3595-241895-H267	267
3595-241895-H268	268
3595-241895-H269	269
3595-241895-H270	270
3595-241895-H271	271
3595-241895-H272	272
3595-241895-H273	273
3595-241895-H274	274
3595-241895-H275	275

PART NUMBER	NUMBER OF HOLES
3595-241895-H276	276
3595-241895-H277	277
3595-241895-H278	278
3595-241895-H279	279
3595-241895-H280	280
3595-241895-H281	281
3595-241895-H282	282
3595-241895-H283	283
3595-241895-H284	284
3595-241895-H285	285
3595-241895-H286	286
3595-241895-H287	287
3595-241895-H288	288
3595-241895-H289	289
3595-241895-H290	290
3595-241895-H291	291
3595-241895-H292	292
3595-241895-H293	293
3595-241895-H294	294
3595-241895-H295	295
3595-241895-H296	296
3595-241895-H297	297
3595-241895-H298	298
3595-241895-H299	299
3595-241895-H300	300

MATERIAL: SEE NOTE 1	TOLERANCES ON DIMENSIONS UNLESS OTHERWISE SPECIFIED		
HEAT TREAT: TEMPER COND. T6	$X^* = \pm 2^*$ $.XX = \pm .015$ MACHINE FINISH = .125 $X/X = \pm 1/32$ $.XXX = \pm .010$		
FINISH: NONE	PART NO. SEE TABLES	DRN <i>Frank Basile</i> DATE 04-10-13	
<small>THE FASTENER PARTS SHOWN IN THIS PRINT ARE PROPRIETARY ARTICLES TO WHICH DFCI SOLUTIONS INC., RETAINS THE EXCLUSIVE RIGHTS OF MANUFACTURE, USE AND SALE. THE PRINT OR DRAWING IS SUBMITTED IN CONFIDENCE AND DOES NOT CONVEY A LICENSE OR PERMISSION TO MANUFACTURE THE FASTENER OR FASTENER PARTS.</small> (C) COPYRIGHT 2009, DFCI SOLUTIONS INC. ALL RIGHTS RESERVED.		CHK. <i>Frank Basile</i> DATE 04-10-13	
		ENG. <i>Robert Alldred</i> DATE 04-10-13	
		MFG. <i>Rashid Isbani</i> DATE 04-10-13	
	NEXT ASSY USED ON	G.C. <i>Robert Alldred</i> DATE 04-10-13	
	APPLICATION BLOCK	SALES.	DATE

		DFCI SOLUTIONS INC. 425 UNION BOULEVARD. WEST ISLIP, NEW YORK 11795	
TITLE PA-3500 RECEPTACLE STRIP 3595-241895-H***			
SIZE A	FSCM NO. 72794	DWG. NO. C3595-241895-H	REV. A
SCALE: NTS		WEIGHT:	SHEET 4 OF 5

UNCONTROLLED

REVISIONS			
SYS	DESCRIPTION	DATE	APPROV
A	INITIAL RELEASE	04-10-13	

PART NUMBER	NUMBER OF HOLES
3595-241895-H301	301
3595-241895-H302	302
3595-241895-H303	303
3595-241895-H304	304
3595-241895-H305	305
3595-241895-H306	306
3595-241895-H307	307
3595-241895-H308	308
3595-241895-H309	309
3595-241895-H310	310
3595-241895-H311	311
3595-241895-H312	312
3595-241895-H313	313
3595-241895-H314	314
3595-241895-H315	315
3595-241895-H316	316
3595-241895-H317	317
3595-241895-H318	318
3595-241895-H319	319
3595-241895-H320	320

NOTES:

- MATERIAL:
RECEPTACLE STRIP: 6061-T6 ALUMINUM ALLOY PER QQ-A-200/8
WIRE: .050 DIA. STAINLESS STEEL TYPE 316 PER ASTM-A-313, SPRING TEMPER
- THE CUT LENGTH OF THE PART IS CALCULATED AS FOLLOWS:
TOTAL LENGTH=(N-1) x (.375) + (.750)
EXAMPLE: 3595-241895-H6 (6-1) x (.375) + (.750) = 2.625 in.
- THE NUMBER OF "N" HOLES PER PART ARE CALLED OUT IN THE PART NUMBER
EXAMPLE: 3595-241895-H6 (H6 INDICATES 6 HOLES)
- SOME DISTORTION MAY ENTER THE .242 DIA. HOLE DUE TO STAKING OF WIRE.
THIS WILL NOT AFFECT THE FUNCTION OF THE PART.
- PLEASE VISIT www.dfcis.com/c3595-241895-h FOR A LIST OF AVAILABLE FINISHES.

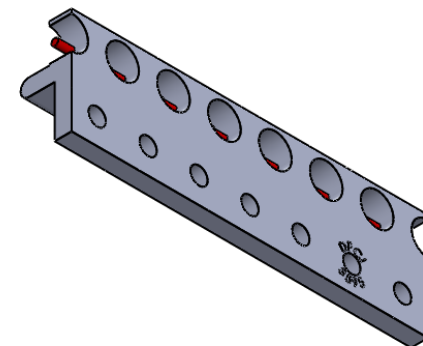

MATERIAL: SEE NOTE 1	TOLERANCES ON DIMENSIONS UNLESS OTHERWISE SPECIFIED X" = ±.2" .XX = ±.015 X/X = ±1/32 .XXX = ±.010 MACHINE FINISH = .125			 DFCI SOLUTIONS INC. 425 UNION BOULEVARD. WEST ISLIP, NEW YORK 11795	TITLE PA-3500 RECEPTACLE STRIP 3595-241895-H***	
HEAT TREAT: TEMPER COND. T6	PART NO. SEE TABLES	DRN <i>Frank Basile</i> DATE 04-10-13	CHK. <i>Frank Basile</i> DATE 04-10-13			
FINISH: NONE		ENG. <i>Robert Alldread</i> DATE 04-10-13	MFG. <i>Rashm Lubman</i> DATE 04-10-13	SIZE A	FSCM NO. 72794	
THE FASTENER PARTS SHOWN IN THIS PRINT ARE PROPRIETARY ARTICLES TO WHICH DFCI SOLUTIONS INC., RETAINS THE EXCLUSIVE RIGHTS OF MANUFACTURE, USE AND SALE. THE PRINT OR DRAWING IS SUBMITTED IN CONFIDENCE AND DOES NOT CONVEY A LICENSE OR PERMISSION TO MANUFACTURE THE FASTENER OR FASTENER PARTS. (C) COPYRIGHT 2009, DFCI SOLUTIONS INC. ALL RIGHTS RESERVED.	NEXT ASSY USED ON APPLICATION BLOCK	Q.C. <i>Robert Alldread</i> DATE 04-10-13	DATE 04-10-13			DWG. NO. C3595-241895-H
			SALES.	SCALE: NTS	WEIGHT:	SHEET 5 OF 5