

UNCONTROLLED

REVISIONS			
SYS	DESCRIPTION	DATE	APPROV
A	INITIAL RELEASE	02-22-12	FB

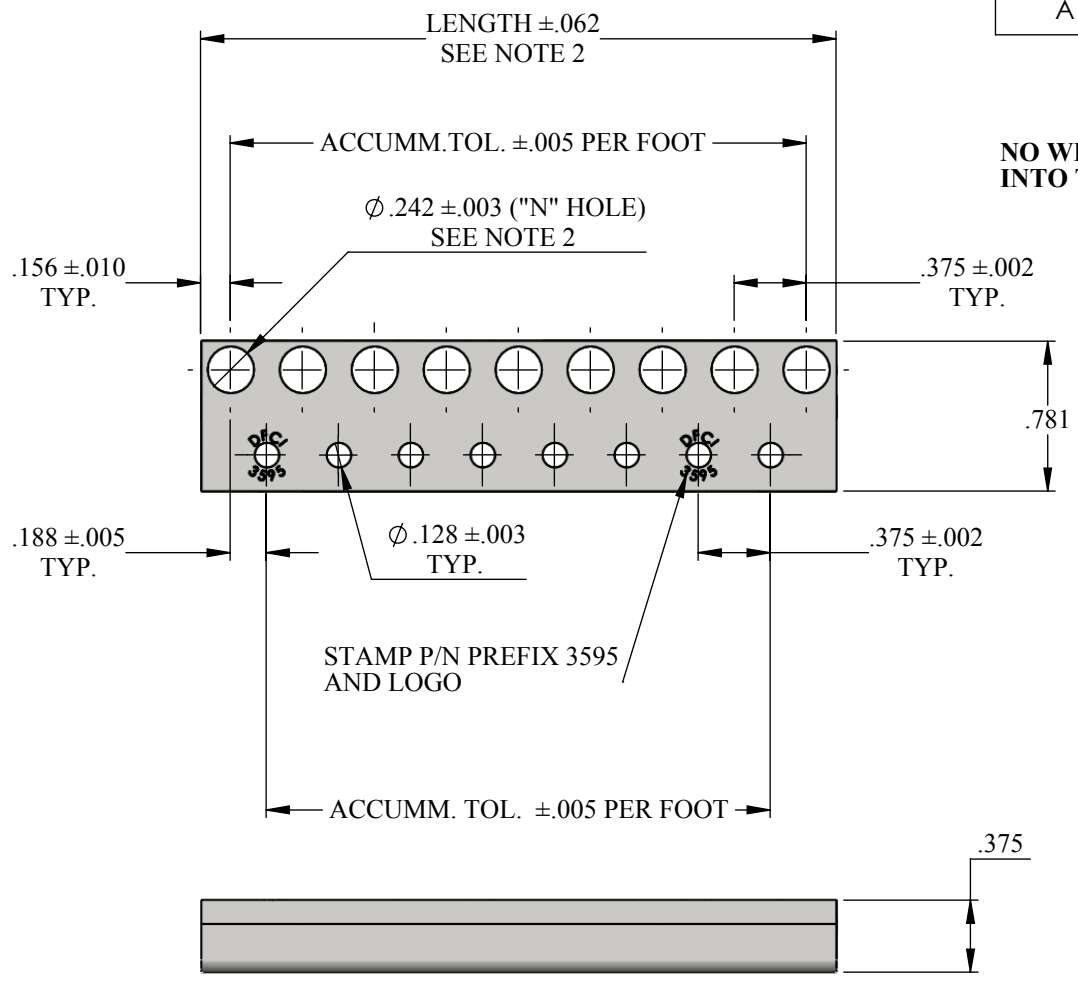

**NO WIRE STAKED
INTO THIS ASSEMBLY**

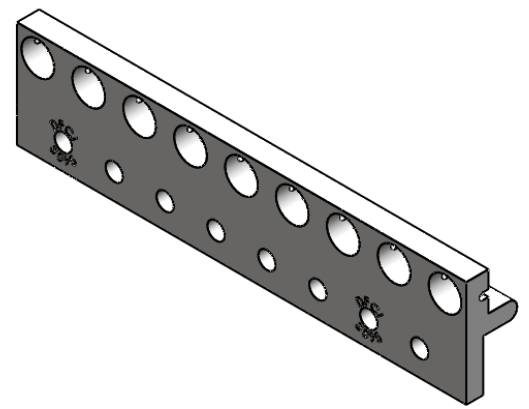
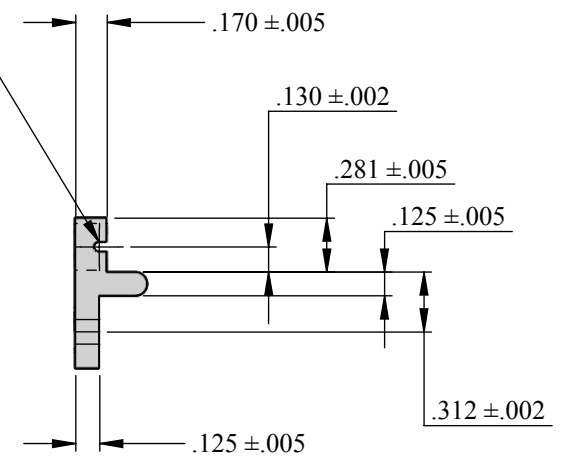

MATERIAL:	SEE NOTE 1 ON SHEET 4 OF 4
HEAT TREAT:	NONE
FINISH:	NONE
<small>THE FASTENER PARTS SHOWN IN THIS PRINT ARE PROPRIETARY ARTICLES TO WHICH DFCI SOLUTIONS INC., RETAINS THE EXCLUSIVE RIGHTS OF MANUFACTURE, USE AND SALE. THE PRINT OR DRAWING IS SUBMITTED IN CONFIDENCE AND DOES NOT CONVEY A LICENSE OR PERMISSION TO MANUFACTURE THE FASTENER OR FASTENER PARTS.</small>	
<small>(C) COPYRIGHT 2009, DFCI SOLUTIONS INC. ALL RIGHTS RESERVED.</small>	

TOLERANCES ON DIMENSIONS UNLESS OTHERWISE SPECIFIED			
<small>X* = ±2°</small>		<small>.XX = ±.015</small>	
<small>X/X = ±1/32</small>		<small>.XXX = ±.010</small>	
<small>MACHINE FINISH = 125T</small>			
PART NO.	SEE TABLE	DRN	DATE
		Frank Basile	02-22-12
		CHK. Frank Basile	02-22-12
		ENG. Peter Alldread	02-22-12
		MFG. Radu Iulianu	02-22-12
		G.C. Peter Alldread	02-22-12
NEXT ASSY	USED ON	SALES.	DATE
APPLICATION BLOCK			

DFCI SOLUTIONS INC.

425 UNION BOULEVARD.
WEST ISLIP, NEW YORK 11795

TITLE		PA-3500 RECEPTACLE STRIP WITH NO WIRE	
		3595-H***-241883	
SIZE	FSCM NO.	DWG. NO.	REV.
A	72794	C3595-H-241883	A
SCALE: NTS		WEIGHT:	SHEET 1 OF 4

UNCONTROLLED

REVISIONS			
SYS	DESCRIPTION	DATE	APPROV
A	INITIAL RELEASE	02-22-12	FB

PART NUMBER	NUMBER OF "N" HOLES
3595-H3-241883	3
3595-H4-241883	4
3595-H5-241883	5
3595-H6-241883	6
3595-H7-241883	7
3595-H8-241883	8
3595-H9-241883	9
3595-H10-241883	10
3595-H11-241883	11
3595-H12-241883	12
3595-H13-241883	13
3595-H14-241883	14
3595-H15-241883	15
3595-H16-241883	16
3595-H17-241883	17
3595-H18-241883	18
3595-H19-241883	19
3595-H20-241883	20
3595-H21-241883	21
3595-H22-241883	22
3595-H23-241883	23
3595-H24-241883	24
3595-H25-241883	25
3595-H26-241883	26
3595-H27-241883	27
3595-H28-241883	28
3595-H29-241883	29
3595-H30-241883	30
3595-H31-241883	31
3595-H32-241883	32
3595-H33-241883	33
3595-H34-241883	34

PART NUMBER	NUMBER OF "N" HOLES
3595-H35-241883	35
3595-H36-241883	36
3595-H37-241883	37
3595-H38-241883	38
3595-H39-241883	39
3595-H40-241883	40
3595-H41-241883	41
3595-H42-241883	42
3595-H43-241883	43
3595-H44-241883	44
3595-H45-241883	45
3595-H46-241883	46
3595-H47-241883	47
3595-H48-241883	48
3595-H49-241883	49
3595-H50-241883	50
3595-H51-241883	51
3595-H52-241883	52
3595-H53-241883	53
3595-H54-241883	54
3595-H55-241883	55
3595-H56-241883	56
3595-H57-241883	57
3595-H58-241883	58
3595-H59-241883	59
3595-H60-241883	60
3595-H61-241883	61
3595-H62-241883	62
3595-H63-241883	63
3595-H64-241883	64
3595-H65-241883	65
3595-H66-241883	66

PART NUMBER	NUMBER OF "N" HOLES
3595-H67-241883	67
3595-H68-241883	68
3595-H69-241883	69
3595-H70-241883	70
3595-H71-241883	71
3595-H72-241883	72
3595-H73-241883	73
3595-H74-241883	74
3595-H75-241883	75
3595-H76-241883	76
3595-H77-241883	77
3595-H78-241883	78
3595-H79-241883	79
3595-H80-241883	80
3595-H81-241883	81
3595-H82-241883	82
3595-H83-241883	83
3595-H84-241883	84
3595-H85-241883	85
3595-H86-241883	86
3595-H87-241883	87
3595-H88-241883	88
3595-H89-241883	89
3595-H90-241883	90
3595-H91-241883	91
3595-H92-241883	92
3595-H93-241883	93
3595-H94-241883	94
3595-H95-241883	95
3595-H96-241883	96
3595-H97-241883	97
3595-H98-241883	98

PART NUMBER	NUMBER OF "N" HOLES
3595-H99-241883	99
3595-H100-241883	100
3595-H101-241883	101
3595-H102-241883	102
3595-H103-241883	103
3595-H104-241883	104
3595-H105-241883	105
3595-H106-241883	106
3595-H107-241883	107
3595-H108-241883	108
3595-H109-241883	109
3595-H110-241883	110
3595-H111-241883	111
3595-H112-241883	112
3595-H113-241883	113
3595-H114-241883	114
3595-H115-241883	115
3595-H116-241883	116
3595-H117-241883	117
3595-H118-241883	118
3595-H119-241883	119
3595-H120-241883	120
3595-H121-241883	121
3595-H122-241883	122
3595-H123-241883	123
3595-H124-241883	124
3595-H125-241883	125
3595-H126-241883	126
3595-H127-241883	127
3595-H128-241883	128
3595-H129-241883	129
3595-H130-241883	130

MATERIAL: SEE NOTE 1 ON SHEET 4 OF 4

HEAT TREAT: NONE

FINISH: NONE

THE FASTENER PARTS SHOWN IN THIS PRINT ARE PROPRIETARY ARTICLES TO WHICH DFCI SOLUTIONS INC., RETAINS THE EXCLUSIVE RIGHTS OF MANUFACTURE, USE AND SALE. THE PRINT OR DRAWING IS SUBMITTED IN CONFIDENCE AND DOES NOT CONVEY A LICENSE OR PERMISSION TO MANUFACTURE THE FASTENER OR FASTENER PARTS.

(C) COPYRIGHT 2009, DFCI SOLUTIONS INC. ALL RIGHTS RESERVED.

TOLERANCES ON DIMENSIONS UNLESS OTHERWISE SPECIFIED

X* = ±2* .XX = ±.015
X/X = ±1/32 .XXX = ±.010

MACHINE FINISH = .125

PART NO.	SEE TABLE	DRN	Frank Basile	DATE	02-22-12
		CHK.	Frank Basile	DATE	02-22-12
		ENG.	Frank Alldorand	DATE	02-22-12
		MFG.	Radu Irbarn	DATE	02-22-12
		G.C.	Frank Alldorand	DATE	02-22-12
NEXT ASSY	USED ON	SALES		DATE	

APPLICATION BLOCK



DFCI SOLUTIONS INC.
425 UNION BOULEVARD.
WEST ISLIP, NEW YORK 11795

TITLE: PA-3500 RECEPTACLE STRIP WITH NO WIRE
3595-H***-241883

SIZE	FSCM NO.	DWG. NO.	REV.
A	72794	C3595-H-241883	A

SCALE: NTS WEIGHT: SHEET 2 OF 4

UNCONTROLLED

REVISIONS			
SYS	DESCRIPTION	DATE	APPROV
A	INITIAL RELEASE	02-22-12	FB

PART NUMBER	NUMBER OF "N" HOLES
3595-H131-241883	131
3595-H132-241883	132
3595-H133-241883	133
3595-H134-241883	134
3595-H135-241883	135
3595-H136-241883	136
3595-H137-241883	137
3595-H138-241883	138
3595-H139-241883	139
3595-H140-241883	140
3595-H141-241883	141
3595-H142-241883	142
3595-H143-241883	143
3595-H144-241883	144
3595-H145-241883	145
3595-H146-241883	146
3595-H147-241883	147
3595-H148-241883	148
3595-H149-241883	149
3595-H150-241883	150
3595-H151-241883	151
3595-H152-241883	152
3595-H153-241883	153
3595-H154-241883	154
3595-H155-241883	155
3595-H156-241883	156
3595-H157-241883	157
3595-H158-241883	158
3595-H159-241883	159
3595-H160-241883	160
3595-H161-241883	161
3595-H162-241883	162

PART NUMBER	NUMBER OF "N" HOLES
3595-H163-241883	163
3595-H164-241883	164
3595-H165-241883	165
3595-H166-241883	166
3595-H167-241883	167
3595-H168-241883	168
3595-H169-241883	169
3595-H170-241883	170
3595-H171-241883	171
3595-H172-241883	172
3595-H173-241883	173
3595-H174-241883	174
3595-H175-241883	175
3595-H176-241883	176
3595-H177-241883	177
3595-H178-241883	178
3595-H179-241883	179
3595-H180-241883	180
3595-H181-241883	181
3595-H182-241883	182
3595-H183-241883	183
3595-H184-241883	184
3595-H185-241883	185
3595-H186-241883	186
3595-H187-241883	187
3595-H188-241883	188
3595-H189-241883	189
3595-H190-241883	190
3595-H191-241883	191
3595-H192-241883	192
3595-H193-241883	193
3595-H194-241883	194

PART NUMBER	NUMBER OF "N" HOLES
3595-H195-241883	195
3595-H196-241883	196
3595-H197-241883	197
3595-H198-241883	198
3595-H199-241883	199
3595-H200-241883	200
3595-H201-241883	201
3595-H202-241883	202
3595-H203-241883	203
3595-H204-241883	204
3595-H205-241883	205
3595-H206-241883	206
3595-H207-241883	207
3595-H208-241883	208
3595-H209-241883	209
3595-H210-241883	210
3595-H211-241883	211
3595-H212-241883	212
3595-H213-241883	213
3595-H214-241883	214
3595-H215-241883	215
3595-H216-241883	216
3595-H217-241883	217
3595-H218-241883	218
3595-H219-241883	219
3595-H220-241883	220
3595-H221-241883	221
3595-H222-241883	222
3595-H223-241883	223
3595-H224-241883	224
3595-H225-241883	225
3595-H226-241883	226

PART NUMBER	NUMBER OF "N" HOLES
3595-H227-241883	227
3595-H228-241883	228
3595-H229-241883	229
3595-H230-241883	230
3595-H231-241883	231
3595-H232-241883	232
3595-H233-241883	233
3595-H234-241883	234
3595-H235-241883	235
3595-H236-241883	236
3595-H237-241883	237
3595-H238-241883	238
3595-H239-241883	239
3595-H240-241883	240
3595-H241-241883	241
3595-H242-241883	242
3595-H243-241883	243
3595-H244-241883	244
3595-H245-241883	245
3595-H246-241883	246
3595-H247-241883	247
3595-H248-241883	248
3595-H249-241883	249
3595-H250-241883	250
3595-H251-241883	251
3595-H252-241883	252
3595-H253-241883	253
3595-H254-241883	254
3595-H255-241883	255
3595-H256-241883	256
3595-H257-241883	257
3595-H258-241883	258

MATERIAL: SEE NOTE 1 ON SHEET 4 OF 4

TOLERANCES ON DIMENSIONS UNLESS OTHERWISE SPECIFIED

HEAT TREAT: NONE

X* = ±2* .XX = ±.015
X/X = ±1/32 .XXX = ±.010 MACHINE FINISH = .125

FINISH: NONE

PART NO. SEE TABLE DRN *Frank Basile* DATE 02-22-12

THE FASTENER PARTS SHOWN IN THIS PRINT ARE PROPRIETARY ARTICLES TO WHICH DFCI SOLUTIONS INC., RETAINS THE EXCLUSIVE RIGHTS OF MANUFACTURE, USE AND SALE. THE PRINT OR DRAWING IS SUBMITTED IN CONFIDENCE AND DOES NOT CONVEY A LICENSE OR PERMISSION TO MANUFACTURE THE FASTENER OR FASTENER PARTS.

CHK. *Frank Basile* DATE 02-22-12

NEXT ASSY USED ON

ENG. *Robert Alldred* DATE 02-22-12

APPLICATION BLOCK

MFG. *Rashm Lubman* DATE 02-22-12

(C) COPYRIGHT 2009, DFCI SOLUTIONS INC. ALL RIGHTS RESERVED.

G.C. *Robert Alldred* DATE 02-22-12

SALES. DATE



DFCI SOLUTIONS INC.
425 UNION BOULEVARD.
WEST ISLIP, NEW YORK 11795

TITLE PA-3500 RECEPTACLE STRIP WITH NO WIRE
3595-H***-241883

SIZE A FSCM NO 72794 DWG. NO. C3595-H-241883 REV. A

SCALE: NTS WEIGHT: SHEET 3 OF 4

UNCONTROLLED

PART NUMBER	NUMBER OF "N" HOLES
3595-H259-241883	259
3595-H260-241883	260
3595-H261-241883	261
3595-H262-241883	262
3595-H263-241883	263
3595-H264-241883	264
3595-H265-241883	265
3595-H266-241883	266
3595-H267-241883	267
3595-H268-241883	268
3595-H269-241883	269
3595-H270-241883	270
3595-H271-241883	271
3595-H272-241883	272
3595-H273-241883	273
3595-H274-241883	274
3595-H275-241883	275
3595-H276-241883	276
3595-H277-241883	277
3595-H278-241883	278
3595-H279-241883	279
3595-H280-241883	280
3595-H281-241883	281
3595-H282-241883	282
3595-H283-241883	283
3595-H284-241883	284
3595-H285-241883	285
3595-H286-241883	286
3595-H287-241883	287
3595-H288-241883	288
3595-H289-241883	289
3595-H290-241883	290

PART NUMBER	NUMBER OF "N" HOLES
3595-H291-241883	291
3595-H292-241883	292
3595-H293-241883	293
3595-H294-241883	294
3595-H295-241883	295
3595-H296-241883	296
3595-H297-241883	297
3595-H298-241883	298
3595-H299-241883	299
3595-H300-241883	300
3595-H301-241883	301
3595-H302-241883	302
3595-H303-241883	303
3595-H304-241883	304
3595-H305-241883	305
3595-H306-241883	306
3595-H307-241883	307
3595-H308-241883	308
3595-H309-241883	309
3595-H310-241883	310
3595-H311-241883	311
3595-H312-241883	312
3595-H313-241883	313
3595-H314-241883	314
3595-H315-241883	315
3595-H316-241883	316
3595-H317-241883	317
3595-H318-241883	318
3595-H319-241883	319
3595-H320-241883	320

REVISIONS			
SYS	DESCRIPTION	DATE	APPROV
A	INITIAL RELEASE	02-22-12	FB

NOTES:

- MATERIAL : 6061-T6 ALUMINUM ALLOY PER QQ-A-200/8
- THE CUT LENGTH IS CALCULATED AS FOLLOWS:
 TOTAL LENGTH = (N-1)(.375)+.312
 EXAMPLE: 3595-H50-241883
 (50-1)(.375)+.312=18.687in.
 THE NUMBER OF HOLES PER PART ARE CALLED OUT IN THE PART NUMBER.
 EXAMPLE: 3595-H50-241883 (-H50 INDICATES 50 HOLES IN THE RECEPTACLE.

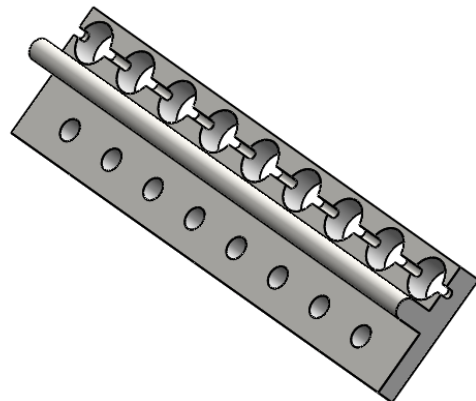

MATERIAL:	SEE NOTE 1 ON SHEET 4 OF 4
HEAT TREAT:	NONE
FINISH:	NONE
<small>THE FASTENER PARTS SHOWN IN THIS PRINT ARE PROPRIETARY ARTICLES TO WHICH DFCI SOLUTIONS INC., RETAINS THE EXCLUSIVE RIGHTS OF MANUFACTURE, USE AND SALE. THE PRINT OR DRAWING IS SUBMITTED IN CONFIDENCE AND DOES NOT CONVEY A LICENSE OR PERMISSION TO MANUFACTURE THE FASTENER OR FASTENER PARTS.</small>	
<small>(C) COPYRIGHT 2009, DFCI SOLUTIONS INC. ALL RIGHTS RESERVED.</small>	

TOLERANCES ON DIMENSIONS UNLESS OTHERWISE SPECIFIED			
X" = ±.2"	.XX = ±.015	MACHINE FINISH = .125/7	
X/X = ±1/32	.XXX = ±.010		
PART NO.	SEE TABLE	DRN	DATE
		Frank Basile	02-22-12
		CHK. Frank Basile	02-22-12
		ENG. <i>Frank Altabrand</i>	02-22-12
		MFG. <i>Rashm Luberman</i>	02-22-12
		Q.C. <i>Frank Altabrand</i>	02-22-12
NEXT ASSY	USED ON	SALES.	DATE
			02-22-12
APPLICATION BLOCK			



DFCI SOLUTIONS INC.
 425 UNION BOULEVARD.
 WEST ISLIP, NEW YORK 11795

TITLE PA-3500 RECEPTACLE STRIP WITH NO WIRE
 3595-H***-241883

SIZE	FSCM NO.	DWG. NO.	REV.
A	72794	C3595-H-241883	A

SCALE: NTS WEIGHT: SHEET 4 OF 4