

UNCONTROLLED

C4604 REV. B

REVISIONS			
SYM	DESCRIPTION	DATE	APPROV
B	CHNG DWG TITLE BLCK, #1061	10-4-07	<i>FB</i>

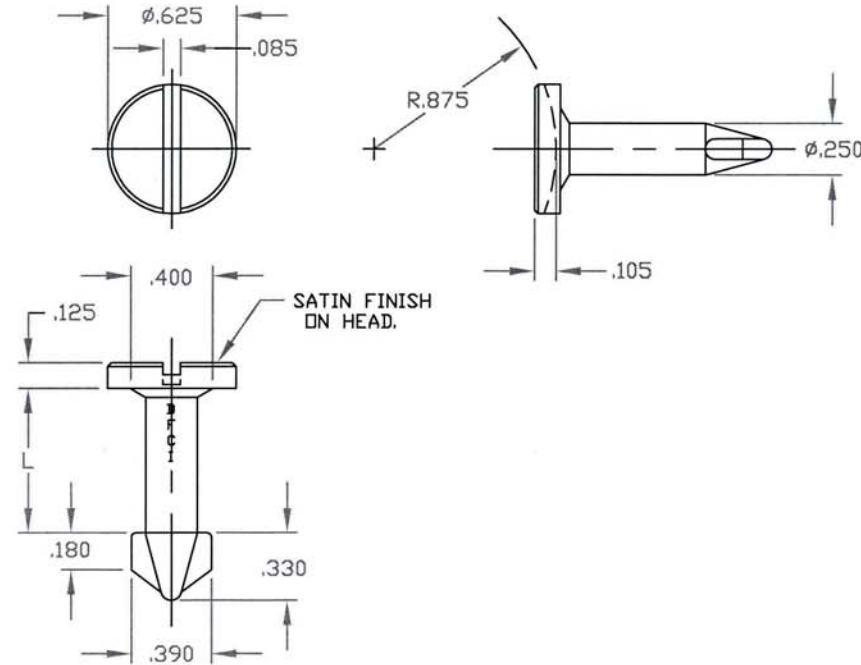

PART NO.	L	COLOR
4604-45-BK	.450	STANDARD BLACK (SEE NOTE 1.)
4604-50-BK	.500	
4604-55-BK	.550	
4604-60-BK	.600	
4604-65-BK	.650	
4604-70-BK	.700	
4604-75-BK	.750	
4604-80-BK	.800	
4604-85-BK	.850	
4604-90-BK	.900	
4604-95-BK	.950	
4604-100-BK	1.000	
4604-105-BK	1.050	
4604-110-BK	1.100	
4604-112-BK	1.120	
4604-130-BK	1.300	

NOTE:

1. CUSTOM COLORS ARE DONE ON SPECIAL ORDERS.

MAT'L ACETAL COPOLYMER RESIN.	TOLERANCES ON DIMENSIONS UNLESS OTHERWISE SPECIFIED X* = ±2* .XX = ±.015 X/X = ±1/32 .XXX = ±.010		MACHINE FINISH 125T		DFCI SOLUTIONS INC. 425 UNION BOULEVARD WEST ISLIP, NEW YORK 11795
HEAT TREAT NONE.	PART NO.	DRN S. FRANKIC	DATE 10-7-04	TITLE DA-4600 LINE FASTENER, 4604-xx-BK.	
FINISH -----		CHK F. Basi	DATE 10-4-07	SIZE A	FSCM NO 72794
		ENG MADHU KOLHAPUR	DATE 10-4-07	DWG. NO. C4604	REV. B
		MFG Bill	DATE 10-4-07	SCALE NTS	WT.
	NEXT ASSY	USED ON	DATE 10-4-07	SHEET 1 OF 1	
	APPLICATION BLOCK	SALES	DATE		

DATE: 07/01/06 FORM: DRAWING