

UNCONTROLLED

C4644 REV. A ▼

REVISIONS			
SYM	DESCRIPTION	DATE	APPROV
A	INITIAL RELEASE PER ECN 845	10-3-08	R-C

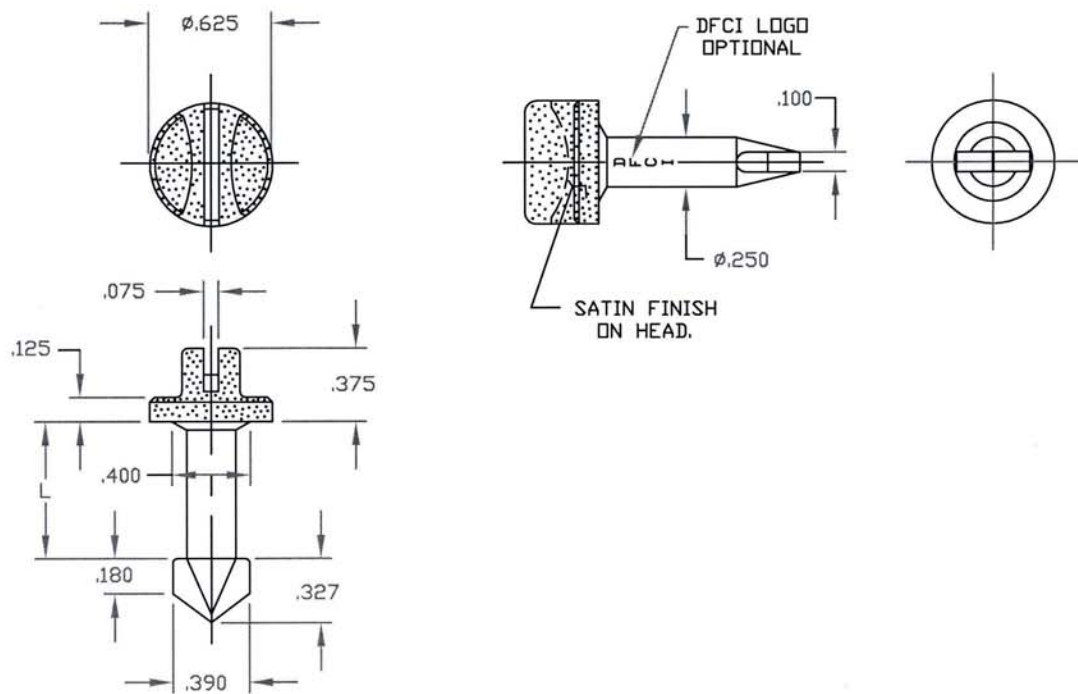

PART NO.	L	COLOR
4644-45-BK	.450	BLACK (STANDARD)
4644-50-BK	.500	
4644-55-BK	.550	
4644-60-BK	.600	
4644-65-BK	.650	
4644-70-BK	.700	
4644-75-BK	.750	
4644-80-BK	.800	
4644-85-BK	.850	
4644-90-BK	.900	
4644-95-BK	.950	
4644-100-BK	1.000	
4644-110-BK	1.100	

NOTES:
 1. MATERIAL: ACETAL COPOLYMER RESIN, GRADE M90.
 2. CUSTOM COLORS ARE DONE ON SPECIAL ORDERS.

MAT'L PER NOTE 1.	TOLERANCES ON DIMENSIONS UNLESS OTHERWISE SPECIFIED $X = \pm 2^*$.XX $\pm .015$ $X/X = \pm 1/32$.XXX $\pm .010$ MACHINE FINISH 125/		 DFCI SOLUTIONS INC. 425 UNION BOULEVARD WEST ISLIP, NEW YORK 11795	
HEAT TREAT NONE.	PART NO.	DRN S. FRANZIS	DATE 10-3-08	TITLE DA-4600 SLOTTED KNOB, 4644-xx-BK.
FINISH CLEAN & FREE OF BURRS.		CHK F. Basal	DATE 10-6-08	
		ENG Frank Gibson	DATE 10-6-08	
		MFG Bill Vel	DATE 10-6-08	
<small>THE FASTENER PARTS SHOWN IN THIS PRINT ARE PROPRIETARY ARTICLES TO WHICH DFCI SOLUTIONS INC. RETAINS THE EXCLUSIVE RIGHTS OF MANUFACTURE, USE AND SALE. THE PRINT OR DRAWING IS SUBMITTED IN CONFIDENCE AND DOES NOT CONVEY A LICENSE OR PERMISSION TO MANUFACTURE THE FASTENER OR FASTENER PARTS.</small> <small>© COPYRIGHT 2003, DFCI SOLUTIONS INC. ALL RIGHTS RESERVED.</small> DATE: 07/01/06 FORM: DRAWING	NEXT ASSY USED ON	SALES B. Lalabala	DATE 10-6-08	SIZE A FSCM NO 72794 DWG. NO. C4644 REV. A SCALE NTS WT. SHEET 1 OF 1