

UNCONTROLLED

C4666 REV. A

| REVISIONS |                             |         |        |
|-----------|-----------------------------|---------|--------|
| SYM       | DESCRIPTION                 | DATE    | APPROV |
| A         | INITIAL RELEASE PER ECN 845 | 10-2-08 | R.C.   |

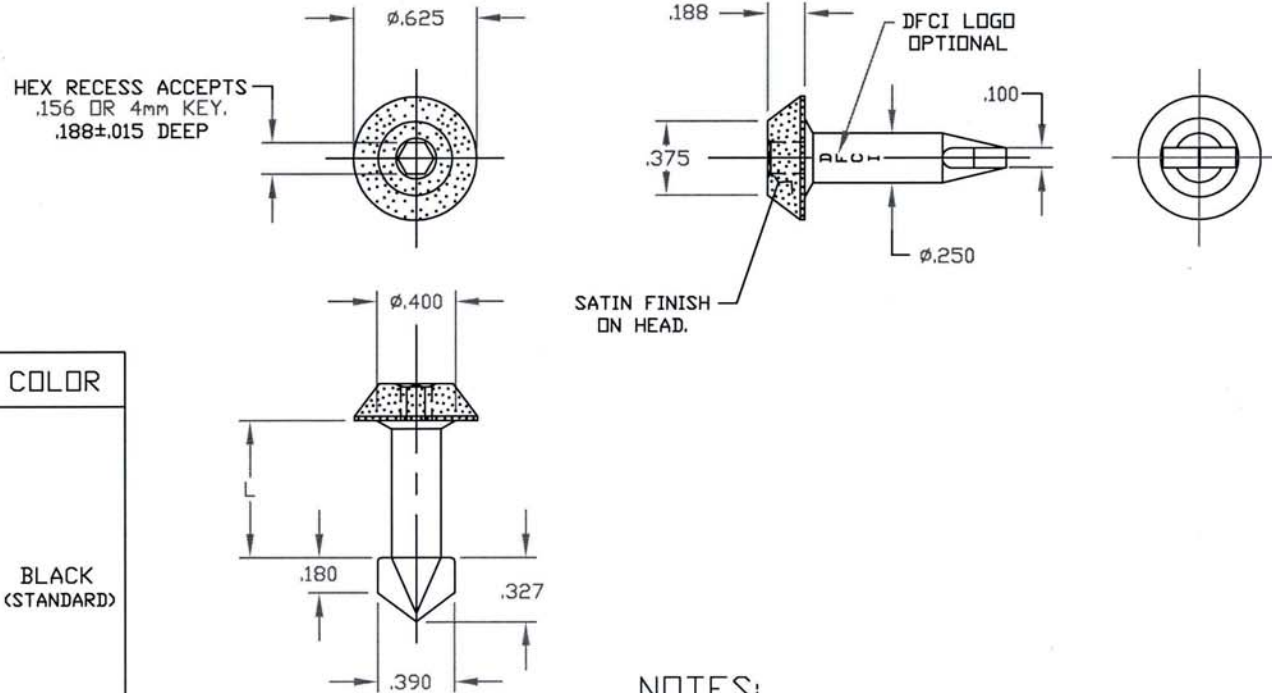

| PART NO.    | L     | COLOR               |
|-------------|-------|---------------------|
| 4666-45-BK  | .450  | BLACK<br>(STANDARD) |
| 4666-50-BK  | .500  |                     |
| 4666-55-BK  | .550  |                     |
| 4666-60-BK  | .600  |                     |
| 4666-65-BK  | .650  |                     |
| 4666-70-BK  | .700  |                     |
| 4666-75-BK  | .750  |                     |
| 4666-80-BK  | .800  |                     |
| 4666-85-BK  | .850  |                     |
| 4666-90-BK  | .900  |                     |
| 4666-95-BK  | .950  |                     |
| 4666-100-BK | 1.000 |                     |
| 4666-110-BK | 1.100 |                     |

- NOTES:
1. MATERIAL: ACETAL COPOLYMER RESIN, GRADE M90.
  2. CUSTOM COLORS ARE DONE ON SPECIAL ORDERS.

|                                  |                                                                                                                             |                   |                                                                          |                                         |
|----------------------------------|-----------------------------------------------------------------------------------------------------------------------------|-------------------|--------------------------------------------------------------------------|-----------------------------------------|
| MAT'L<br>PER NOTE 1.             | TOLERANCES ON DIMENSIONS UNLESS OTHERWISE SPECIFIED<br>X* = ±2* .XX = ±.015<br>X/X = ±1/32 .XXX = ±.010 MACHINE FINISH 125/ |                   | DFCI SOLUTIONS INC.<br>425 UNION BOULEVARD<br>WEST ISLIP, NEW YORK 11795 |                                         |
| HEAT TREAT<br>NONE.              | PART NO.                                                                                                                    | DRN<br>S. FRANCIS | DATE<br>10-2-08                                                          | DA-4600 HEX RECESS STUD,<br>4666-xx-BK. |
| FINISH<br>CLEAN & FREE OF BURRS. |                                                                                                                             | CHK<br>F. Basile  | DATE<br>10-03-08                                                         |                                         |
|                                  |                                                                                                                             | ENG<br>B. Wilson  | DATE<br>10-03-08                                                         | SIZE<br>A                               |
|                                  |                                                                                                                             | MFG<br>B. Wilson  | DATE<br>10-03-08                                                         | FSCM NO<br>72794                        |
|                                  | NEXT ASSY                                                                                                                   | USED ON           | DATE<br>10-3-08                                                          | DWG. NO.<br>C4666                       |
|                                  | APPLICATION BLOCK                                                                                                           | SALES             | DATE                                                                     | REV.<br>A                               |
| DATE: 07/01/06 FORM: DRAWING     |                                                                                                                             |                   | SCALE<br>NTS                                                             | WT.                                     |
|                                  |                                                                                                                             |                   |                                                                          | SHEET 1 OF 1                            |