

UNCONTROLLED

C5714-P SHT. 1 of 2 REV. A

REVISIONS			
SYM	DESCRIPTION	DATE	APPROV
A	INITIAL RELEASE PER ECN 845	2-19-09	<i>FB</i>

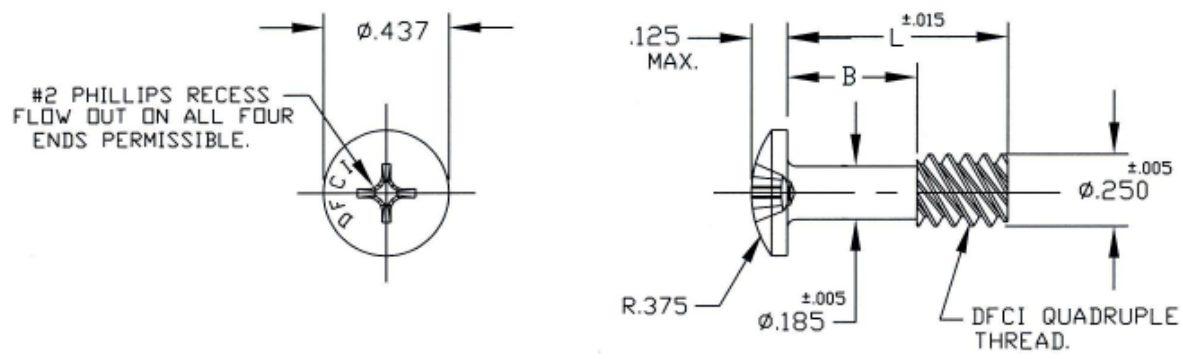

FOR PART NO. REFER TO SHEET 2 of 2.

MAT'L PER A,I,S,I 1117, 8620 STEEL OR TYPE 303 ST. STEEL.	TOLERANCES ON DIMENSIONS UNLESS OTHERWISE SPECIFIED X = $\pm 2^\circ$ .XX = $\pm .015$ X/X = $\pm 1/32$ .XXX = $\pm .010$ MACHINE FINISH .125		DFCI SOLUTIONS INC. 425 UNION BOULEVARD WEST ISLIP, NEW YORK 11795	
HEAT TREAT PER NOTE 1.	PART NO.	DRN S. Francis DATE 2-19-09	TITLE UN-5700 LINE STUD 5714-P20-xx-Z2CT.	
FINISH PER NOTE 2.		CHK F. Basch DATE 4-9-09	SIZE A	FSCM NO 72794
		ENG B. Hildebrand DATE 4-09-09	DWG. NO. C5714-P	REV. A
		MFG B. Hildebrand DATE 4-09-09	SCALE NTS	WT.
	NEXT ASSY	USED ON	SHEET 1 OF 2	
	APPLICATION BLOCK			
		SALES		

DATE: 07/01/06 FORM: DRAWING

The parts shown in this print are proprietary articles to which DFCI Solutions, Inc. retains the exclusive rights of manufacture, use and sale. The print or drawing is submitted in confidence and does not convey a license or permission to manufacture the parts. Copyright © 2009 by DFCI Solutions, Inc. All rights reserved.

UNCONTROLLED

REVISIONS			
SYM	DESCRIPTION	DATE	APPROV
A	INITIAL RELEASE PER ECN 845	2-19-09	<i>FB</i>

NOTES:

- HEAT TREAT:  
STEEL STUD, ROCKWELL C27 - 33.  
STAINLESS STEEL NOT HEAT TREATED.
- FINISH:  
ZINC PLATE PER ASTM-B-633, TYPE III, SC 1,  
CLEAR TRIVALENT CHROMATE WITH SEALER.  
(RoHS COMPLIANT) FINISH SUFFIX: -Z2CT  
THE ABOVE MENTIONED FINISH WILL BE SUPPLIED  
AS THE STANDARD FINISH  
UPON DEPLETION OF EXISTING STOCK WHICH ARE  
FINISHED AS FOLLOW:  
CADMIUM PLATE PER QQ-P-416, TYPE I, CLASS 3,  
CLEAR CHROMATE. (FINISH SUFFIX: -C2C)
- FOR PART NO. OF STUD MADE FROM TYPE 303 ST.  
STEEL, REMOVE SUFFIX -Z2CT FROM P/N AND ADD \*SS\*  
EXAMPLE 5714-P20-10-SS.
- FOR THE APPLICATION OF ALTERNATIVE FINISHES,  
REMOVE SUFFIX -Z2CT FROM THE PART NO.  
AND ADD THE REQUIRED FINISH TO THE PART NO. SUFFIX.  
\*EXAMPLE FOR BLACK ZINC TRIVALENT CHROMATE  
5714-P20-10-Z2BT.
- PLEASE VISIT [WWW.DFCIS.COM/C5714-P](http://WWW.DFCIS.COM/C5714-P) FOR A LIST OF  
AVAILABLE FINISHES.

PART NO. (STEEL STUD)	WEIGHT (LBS.)	B	L
5714-P20-10-Z2CT	.0085	.250	.565
5714-P20-20-Z2CT	.0094	.350	.665
5714-P20-30-Z2CT	.0103	.450	.765
5714-P20-40-Z2CT	.0110	.550	.865
5714-P20-50-Z2CT	.0119	.650	.965
5714-P20-60-Z2CT	.0128	.750	1.065
5714-P20-70-Z2CT	.0137	.850	1.165
5714-P20-80-Z2CT	.0146	.950	1.265
5714-P20-90-Z2CT	.0155	1.050	1.365
5714-P20-100-Z2CT	.0164	1.150	1.465
5714-P20-110-Z2CT	.0173	1.250	1.565
5714-P20-120-Z2CT	.0181	1.350	1.665

MAT'L PER A.I.S.1117, 8620 STEEL OR TYPE 303 ST. STEEL.		TOLERANCES ON DIMENSIONS UNLESS OTHERWISE SPECIFIED $X = \pm 2'$ .XX = $\pm .015$ $X/X = \pm 1/32$ .XXX = $\pm .010$		MACHINE FINISH .125/		DFCI SOLUTIONS INC. 425 UNION BOULEVARD WEST ISLIP, NEW YORK 11795	
HEAT TREAT PER NOTE 1.		PART NO.		DRN S. FRANCIS DATE 2-19-09		TITLE UN-5700 LINE STUD 5714-P20-xx-Z2CT.	
FINISH PER NOTE 2.		CHECKED F. Basile DATE 4-9-09		ENG B. Hildebrand DATE 4-09-09		SIZE A	
MFG B. Hildebrand DATE 4-09-09		DATE 4-09-09		FSCM NO 72794		DWG. NO. C5714-P	
NEXT ASSY		USED ON		SALES DATE		REV. A	
APPLICATION BLOCK		SCALE NTS		WT.		SHEET 2 OF 2	

DATE: 07/01/06 FORM: DRAWING