

UNCONTROLLED

REVISIONS			
SYS	DESCRIPTION	DATE	APPROV
/	INITIAL RELEASE	07-23-13	

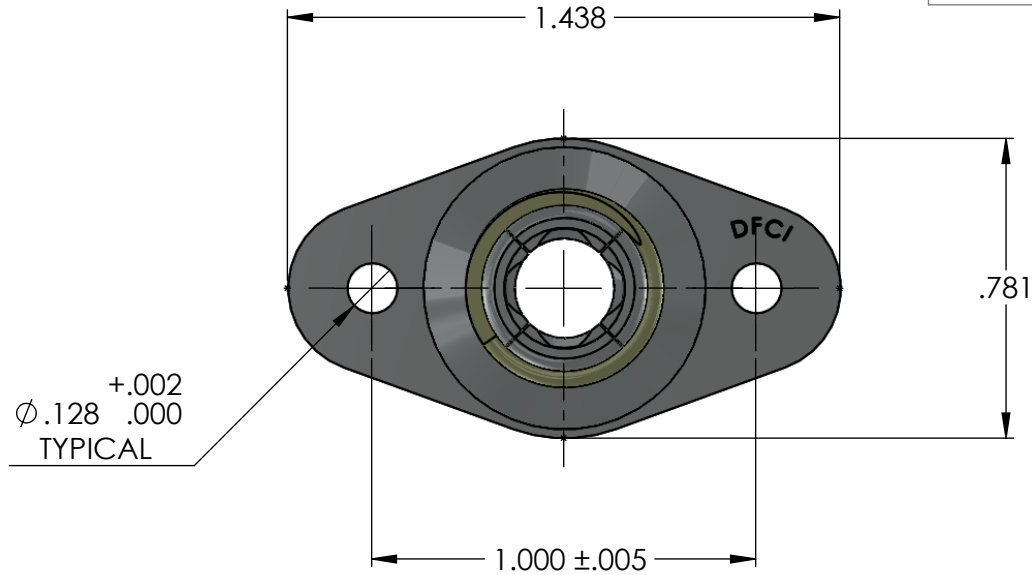

FINISH: BODY-ANODIZED

SPRING- ZINC TRIVALENT CLEAR CHROMATE WITH SEALER PER ASTM-B-633 TYPE III, SC1

THE ABOVE MENTIONED SPRING FINISH WILL BE SUPPLIED AS THE STANDARD FINISH UPON DEPLETION OF EXISTING STOCK WHICH ARE FINISHED AS FOLLOWS: CADMIUM PLATE YELLOW CHROMATE PER QQ-P-416, TYPE II, CLASS 2

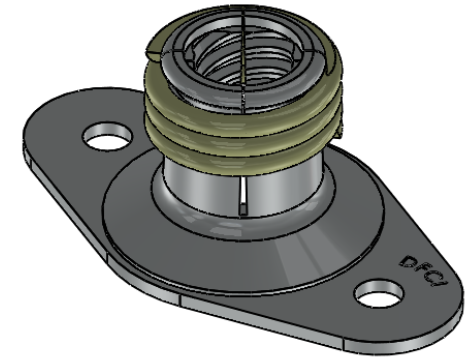
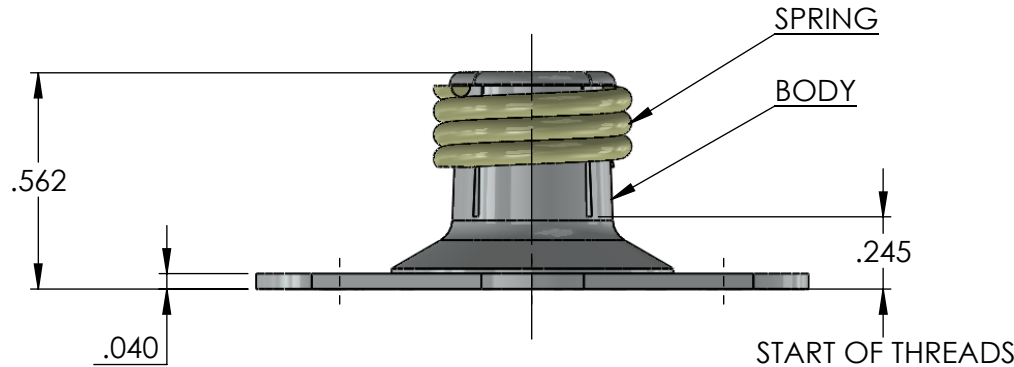

MATERIAL:	BODY: 7075-T6 ALUMINUM ALLOY SPRING: MUSIC WIRE
HEAT TREAT:	NONE
FINISH:	NOTED
<small>THE FASTENER PARTS SHOWN IN THIS PRINT ARE PROPRIETARY ARTICLES TO WHICH DFCI SOLUTIONS INC., RETAINS THE EXCLUSIVE RIGHTS OF MANUFACTURE, USE AND SALE. THE PRINT OR DRAWING IS SUBMITTED IN CONFIDENCE AND DOES NOT CONVEY A LICENSE OR PERMISSION TO MANUFACTURE THE FASTENER OR FASTENER PARTS.</small>	
<small>(C) COPYRIGHT 2009, DFCI SOLUTIONS INC. ALL RIGHTS RESERVED.</small>	

TOLERANCES ON DIMENSIONS UNLESS OTHERWISE SPECIFIED			
	X* = ±2°	.XX = ±.015	MACHINE FINISH = .125
	X/X = ±1/32	.XXX = ±.010	
PART NO.	5718-5-ACNC	DRN	<i>Frank Basile</i> DATE 07-23-13
		CHK.	<i>Frank Basile</i> DATE 07-23-13
		ENG.	<i>Robert Altkorn</i> DATE 07-23-13
		MFG.	<i>Rashid Zuban</i> DATE 07-23-13
		G.C.	<i>Robert Altkorn</i> DATE 07-23-13
NEXT ASSY	USED ON	SALES.	DATE
APPLICATION BLOCK			



DFCI SOLUTIONS INC.
425 UNION BOULEVARD.
WEST ISLIP, NEW YORK 11795

**UN-5700
RECEPTACLE ASSEMBLY**

SIZE	FSCM NO.	DWG. NO.	REV.
A	72794	C5718-5	/

SCALE: NTS

WEIGHT:

SHEET 1 OF 1