

UNCONTROLLED

REVISIONS			
SYS	DESCRIPTION	DATE	APPROV
C	PER ECN 1168	03/31/10	F.B

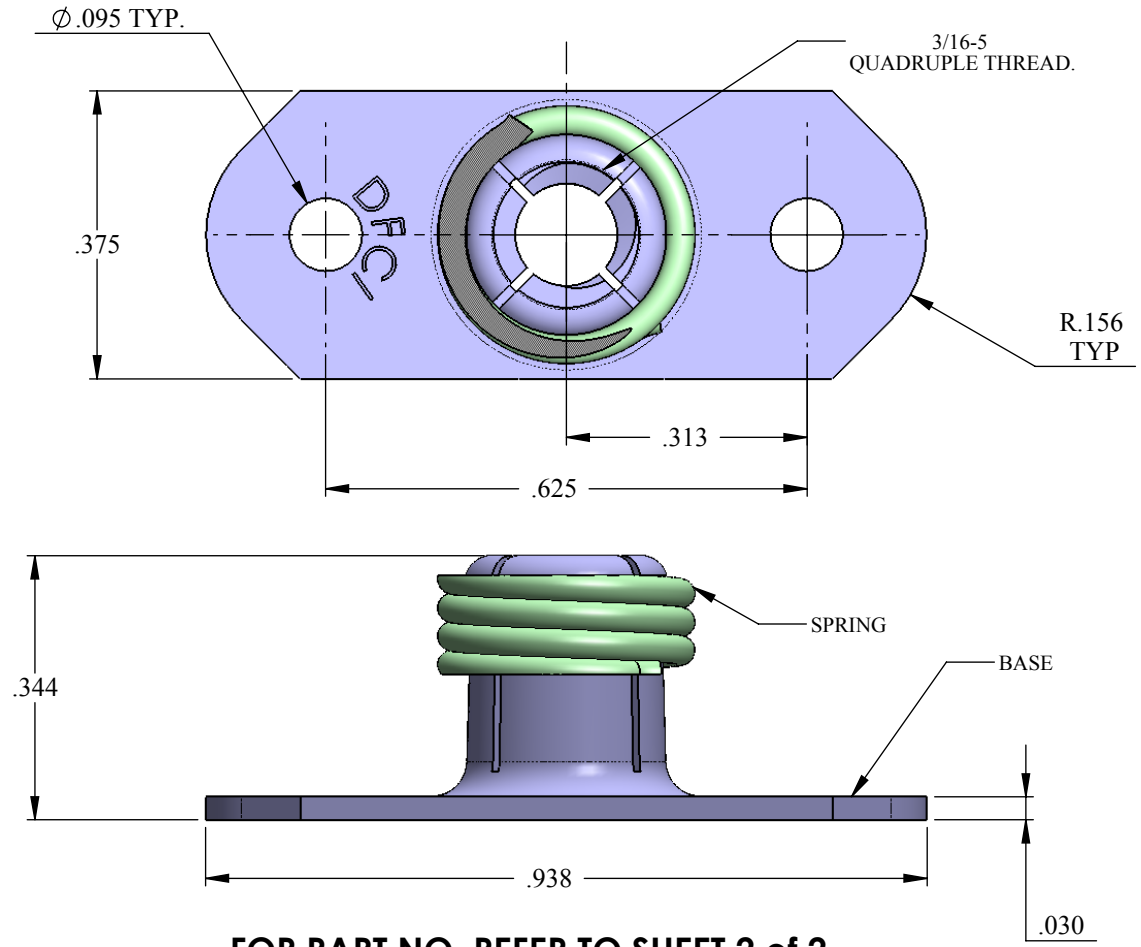

FOR PART NO. REFER TO SHEET 2 of 2

MATERIAL:	AS NOTED ON SHEET 2
HEAT TREAT:	AS NOTED ON SHEET 2
FINISH:	AS NOTED ON SHEET 2
<small>THE FASTENER PARTS SHOWN IN THIS PRINT ARE PROPRIETARY ARTICLES TO WHICH DFCI SOLUTIONS INC., RETAINS THE EXCLUSIVE RIGHTS OF MANUFACTURE, USE AND SALE. THE PRINT OR DRAWING IS SUBMITTED IN CONFIDENCE AND DOES NOT CONVEY A LICENSE OR PERMISSION TO MANUFACTURE THE FASTENER OR FASTENER PARTS.</small>	
<small>(C) COPYRIGHT 2009, DFCI SOLUTIONS INC. ALL RIGHTS RESERVED.</small>	

TOLERANCES ON DIMENSIONS UNLESS OTHERWISE SPECIFIED			
$X^\circ = \pm 2^\circ$		$.XX = \pm .010$	
$X/X = \pm 1/32$		$.XXX = \pm .005$	
MACHINE FINISH = .125			
PART NO.	DRN	W. Zhindon	DATE 03/24/10
	CHK.	Frank Basile	DATE 03/30/10
	ENG.	Bob Albrand	DATE 03/30/10
	MFG.	Bill Velazquez	DATE 03/30/10
	G.C.	Bob Albrand	DATE 03/30/10
NEXT ASSY	USED ON	SALES.	DATE
APPLICATION BLOCK			

DFCI SOLUTIONS INC.
 425 UNION BOULEVARD.
 WEST ISLIP, NEW YORK 11795

TITLE		UN-5700 RECEPTACLE ASSY. 5718-A3-xxx	
SIZE	FSCM NO.	DWG. NO.	REV.
A	72794	C5718-A3	C
SCALE: NTS		WEIGHT:	SHEET 1 OF 2

